

66990 Geisterhaus mit micro-sound Geisterheulen und Lichteffekten H0

Haunted House with micro-sound Ghost Howling and Light Effects H0

Manoir hanté avec micro-sound hurlements de fantômes et effets lumineux H0

Casa del terror con micro-sonido aullidos de fantasmas y efectos luminosos H0

Spookhuis met micro-sound spook gehuil en lichteffecten H0

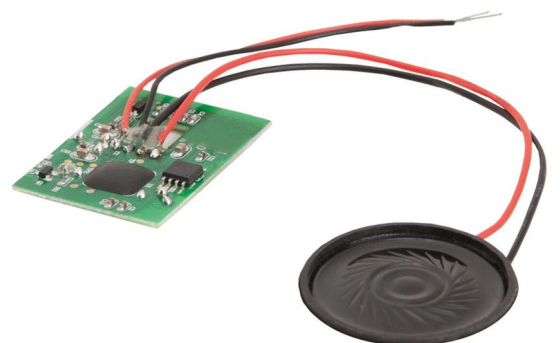

Hinweis:

Durch die liegende Lagerung im Bausatz kann sich der Klebstoff in der Tube nach unten abgesetzt haben, sodass beim ersten Drücken Wasser aus der Tube entweicht. Vor dem ersten Einsatz des Klebers daher bitte die Tube kurz durchkneten und zunächst auf einem Blatt Papier probieren. Für die Verklebung von kleinen Teilen empfehlen wir Ihnen den einzeln erhältlichen NOCH Laser-Cut Kleber (Art.-Nr. 61104) mit der besonders feinen Dosierspitze.

Note:

Owing to the horizontal storage of the glue in the package it is possible that some water will come out when first pressing the tube. Before first use, please knead the tube briefly and make a test on a sheet of paper. For fixing small parts we recommend the NOCH Laser-Cut Adhesive (ref. 61104) with a very fine dosing tip.

Indication:

A cause du stockage horizontal, la colle dans le tube peut se déposer vers le bas de sorte que de l'eau s'échappe du tube en le pressant pour la première fois. Avant le premier usage, il faut donc pétrir le tube et faire un test sur une feuille de papier. Pour le collage des petits éléments, il convient d'utiliser de la colle Laser-Cut NOCH (réf. 61104) avec la fine pointe de dosage.

Nota:

Debido al almacenamiento horizontal del kit, es posible que el pegamento se haya asentado en la base, y que al ejercer la primera presión sobre el tubo salga agua. Por ello antes de usar el pegamento por primera vez, amase el tubo brevemente y pruébelo primero sobre un papel. Para la encolado de piezas pequeñas, recomendamos el pegamento especial para cartón cortado por láser NOCH disponible individualmente (Ref. 61104) con la boquilla dosificadora especialmente fina.

Aanwijzing:

Door het liggend opslaan van de bouwdoos kan de lijm in de tube naar onderen gelopen zijn, waardoor bij de eerste keer drukken water uit de tube komt. Voor gebruik van de lijm daarom eerst de tube kort kneden en dan op een stukje papier uitproberen. Voor het lijmen van kleine onderdelen adviseren wij de los verkrijgbare speciale NOCH laser-cut lijm (art. nr. 61104) met de zeer fijne doseerpunt.

*Dieses Gebäude besteht aus sehr vielen Einzelteilen.
Bitte trennen Sie die Teile erst dann aus der Platte,
wenn der jeweilige Arbeitsschritt erreicht ist. Eine
handschriftliche Nummerierung am Plattenrand kann
sehr hilfreich sein.*

*This building consists of a large number of single parts.
Please do not rip the parts out of the plate before you
need them for the next assembly step.
It can be very useful to number the plates on the edges.*

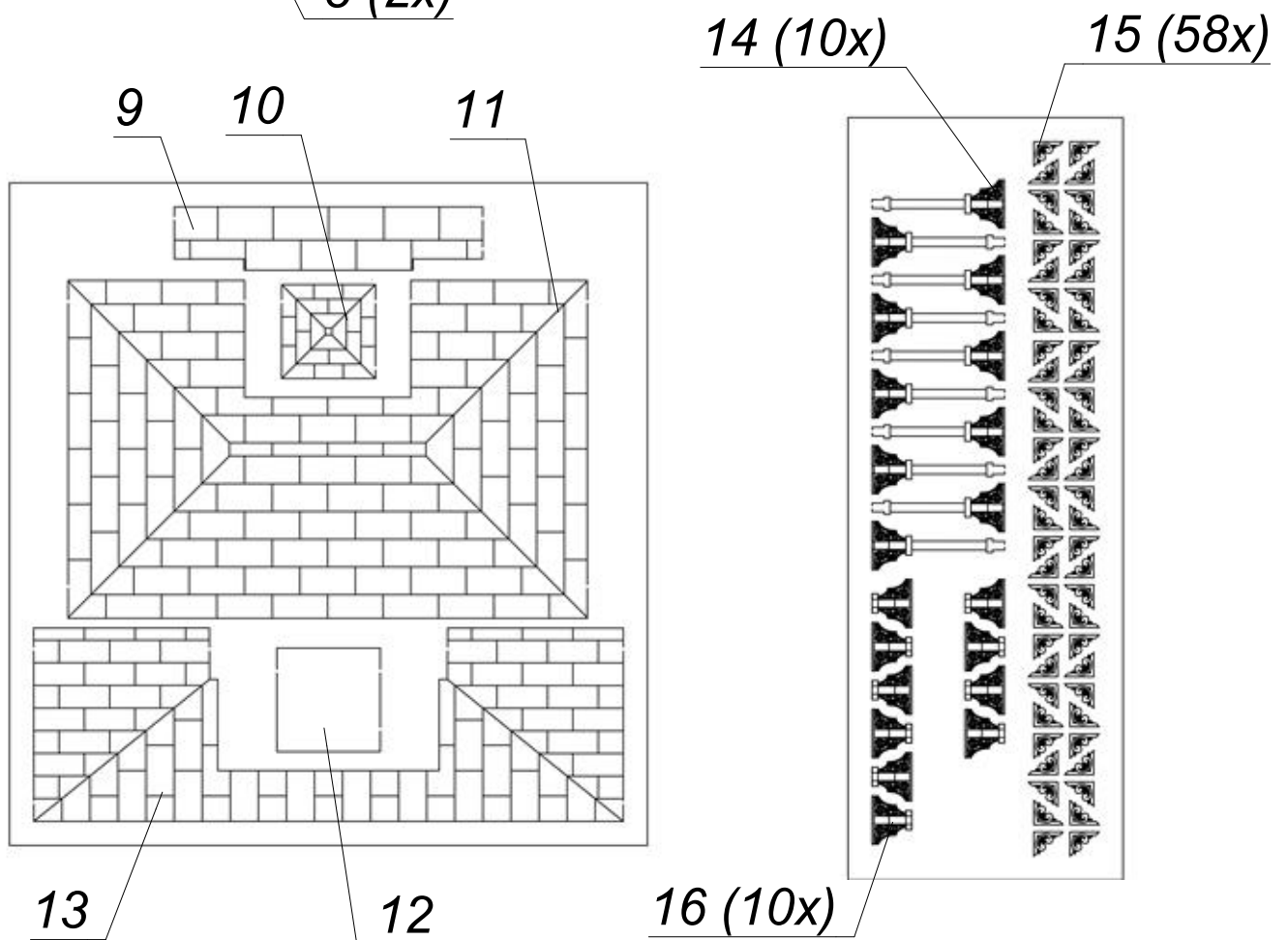
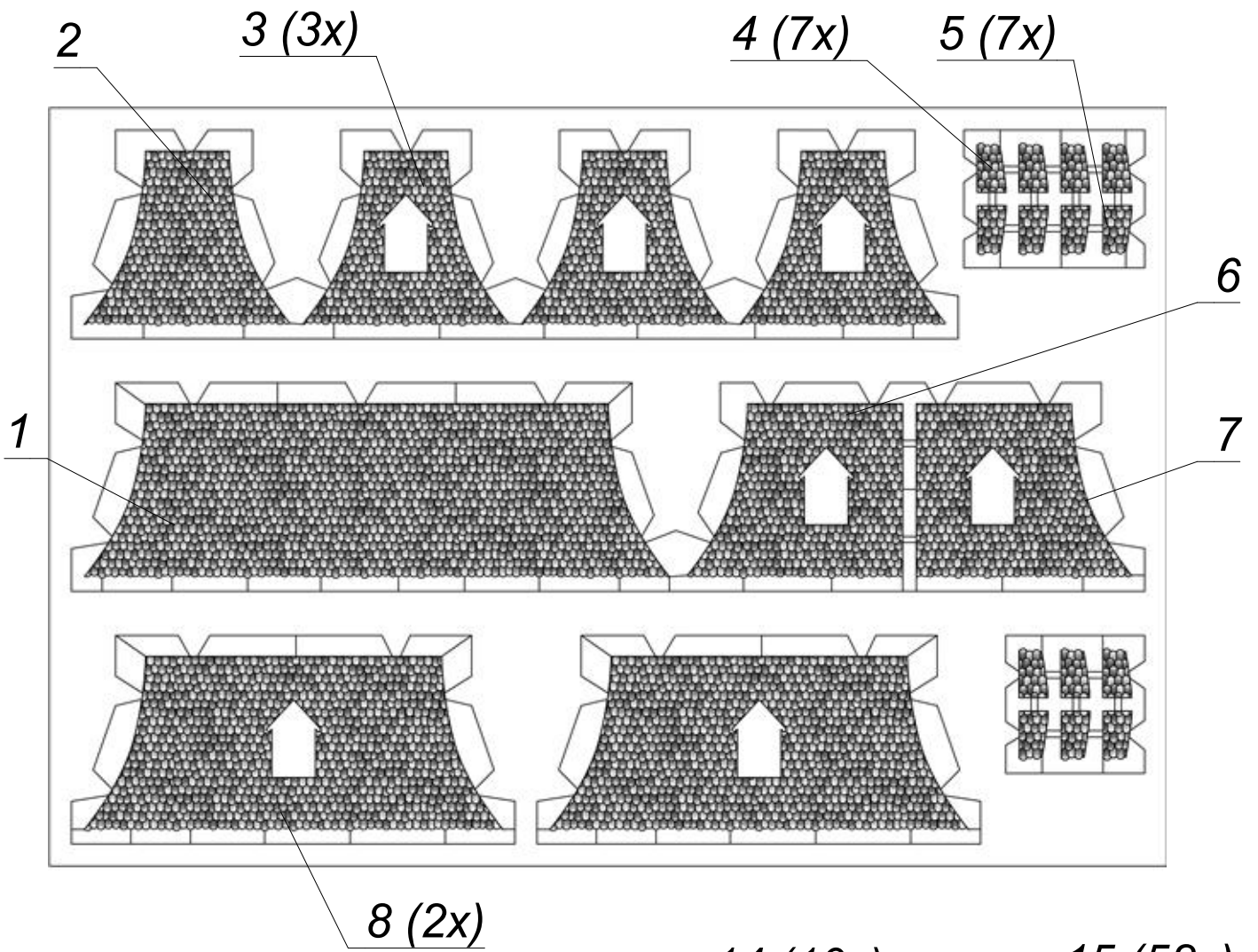

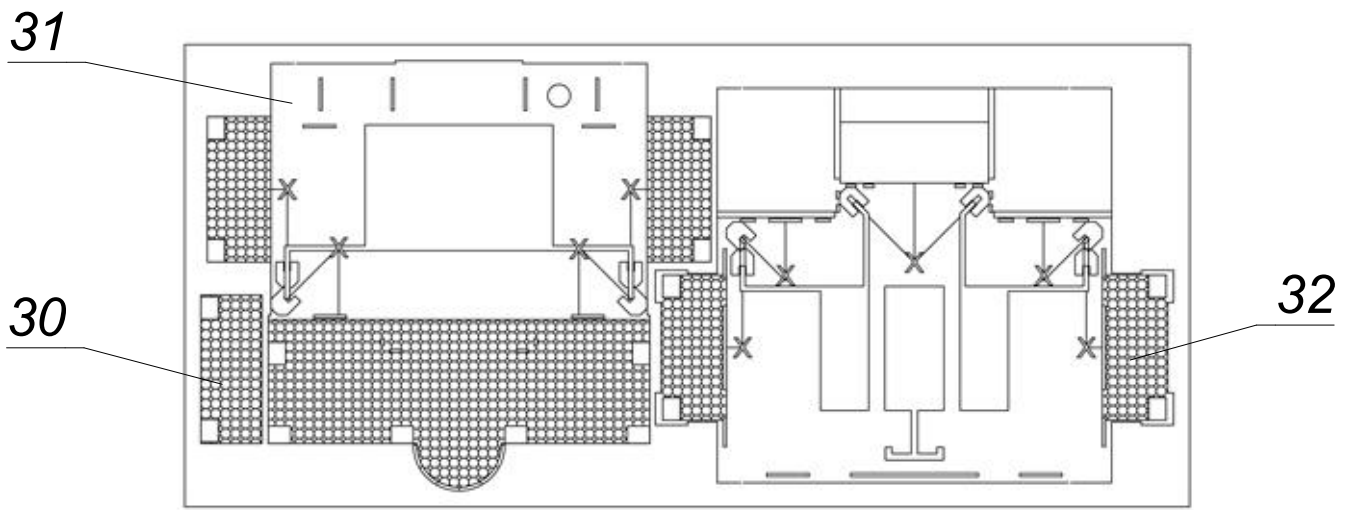
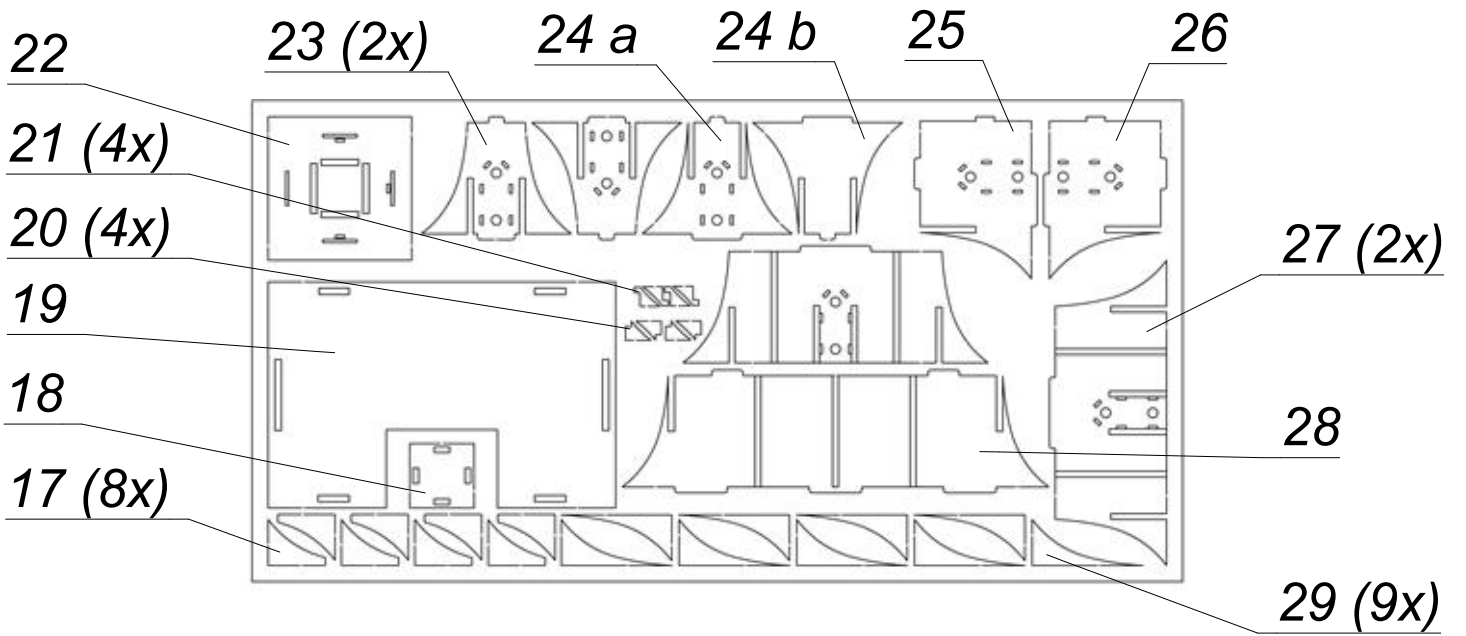

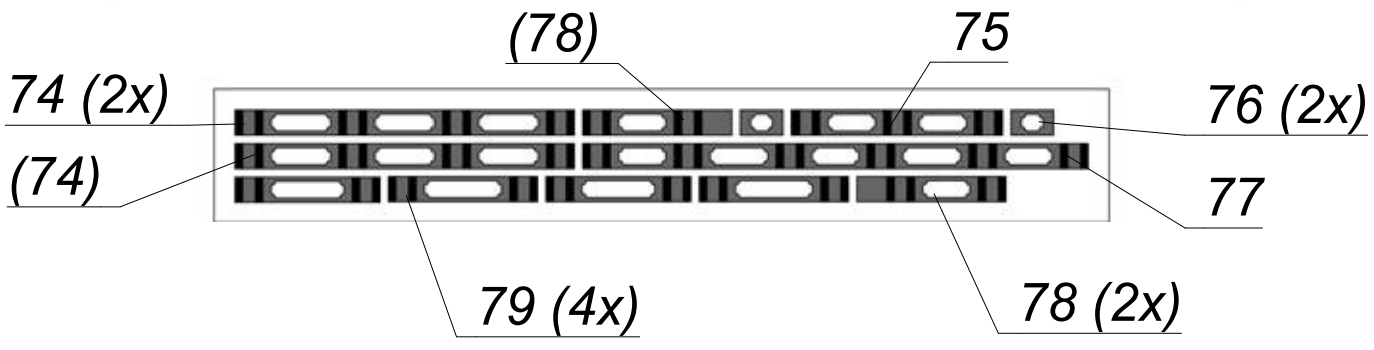
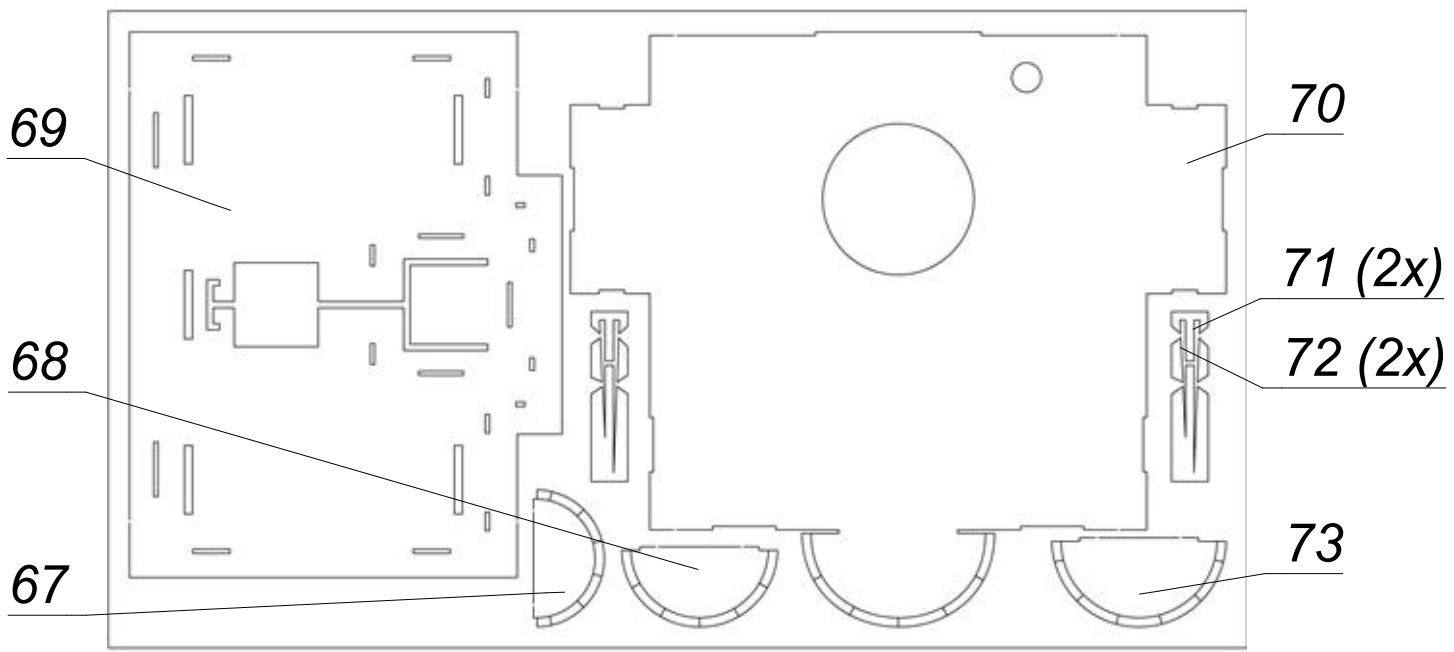
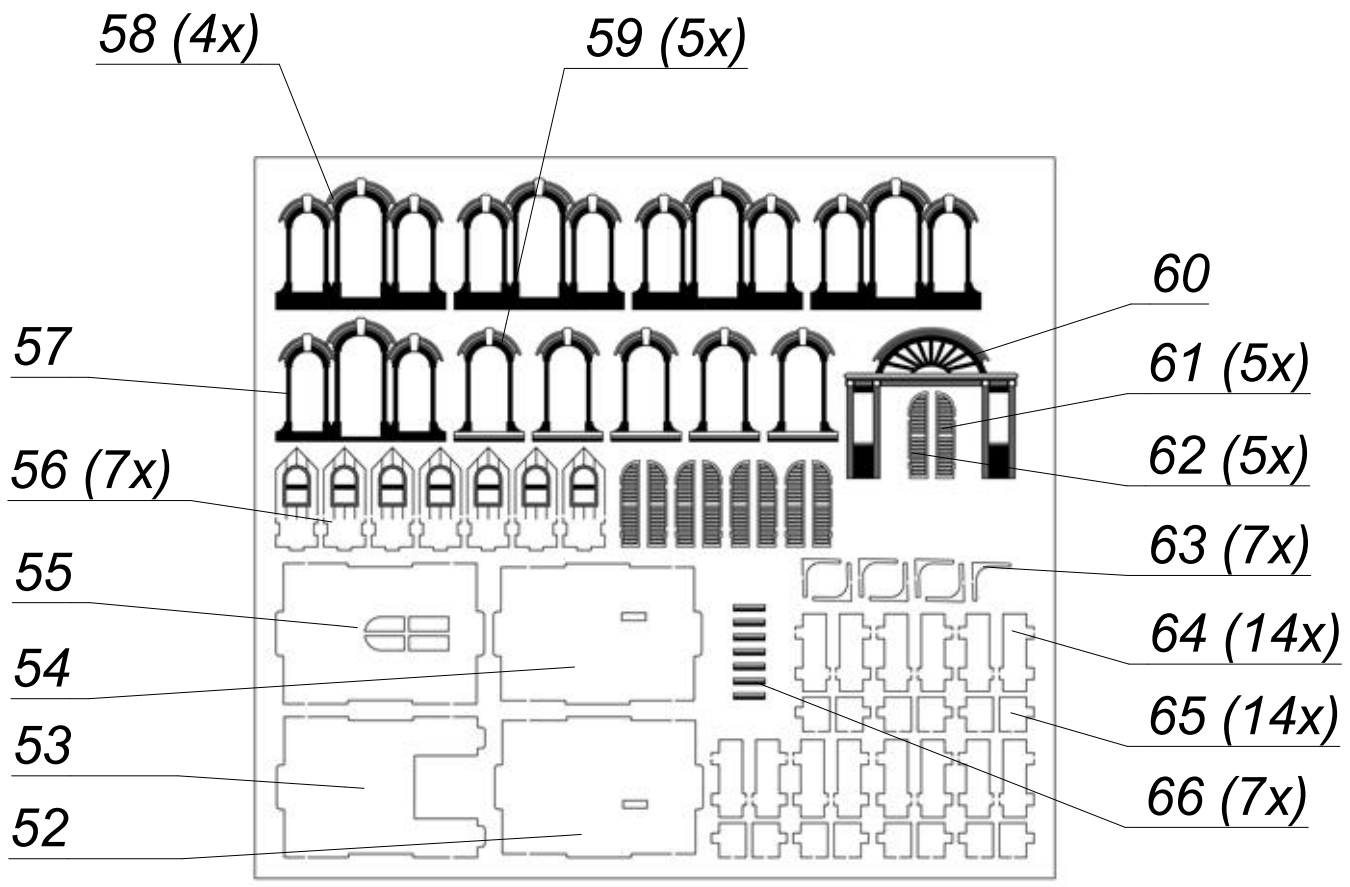

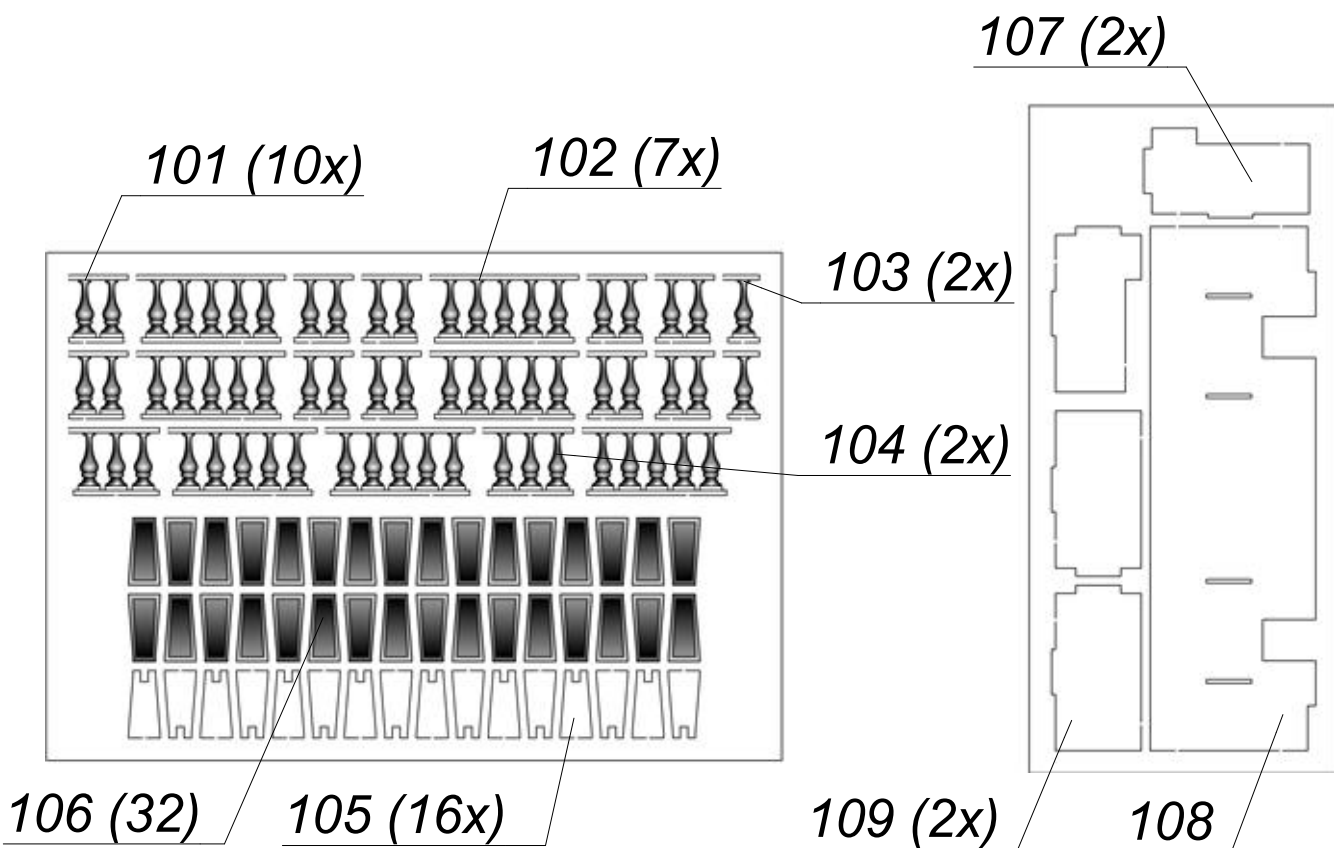
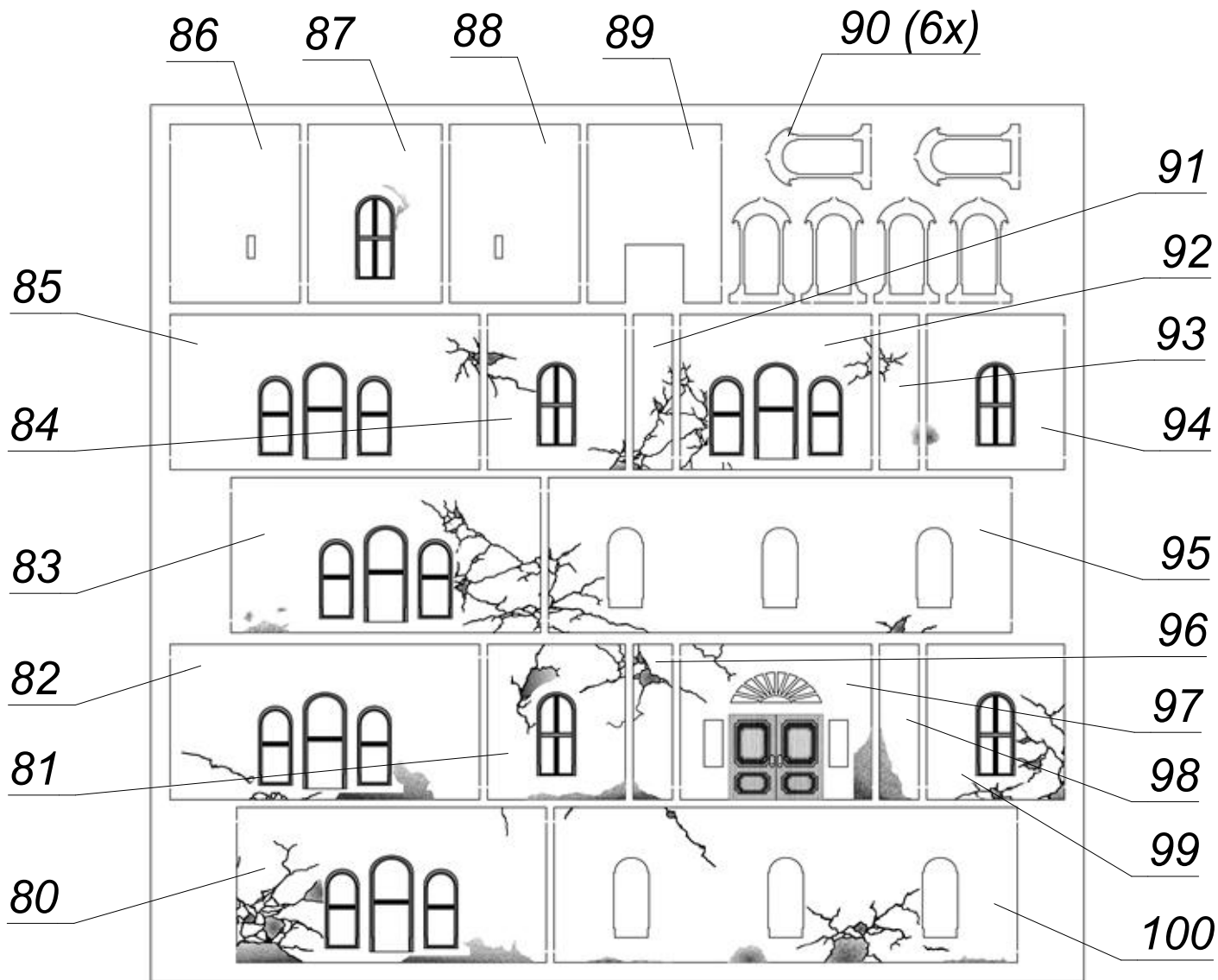

113 (2x)

112 (2x)

111 (4x)

110 (2x)

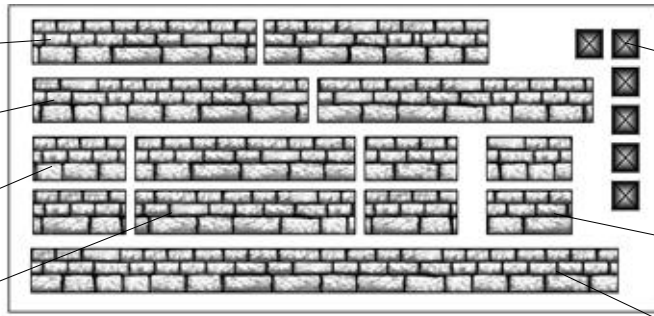

114 (6x)

115 (2x)

116

118

119

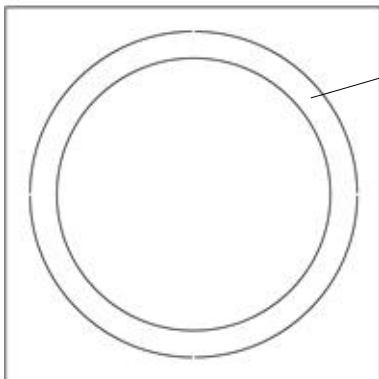

117

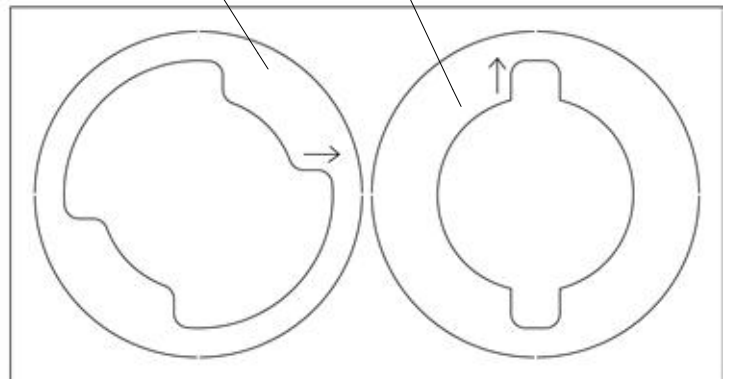

G

F



E



L

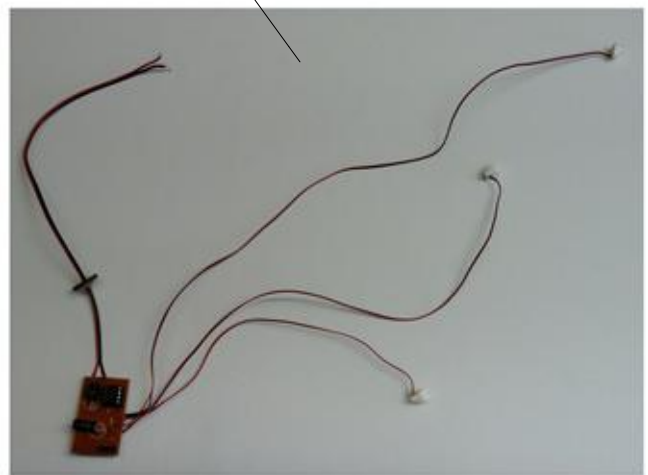

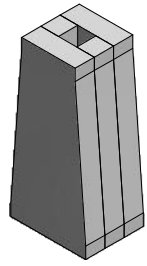
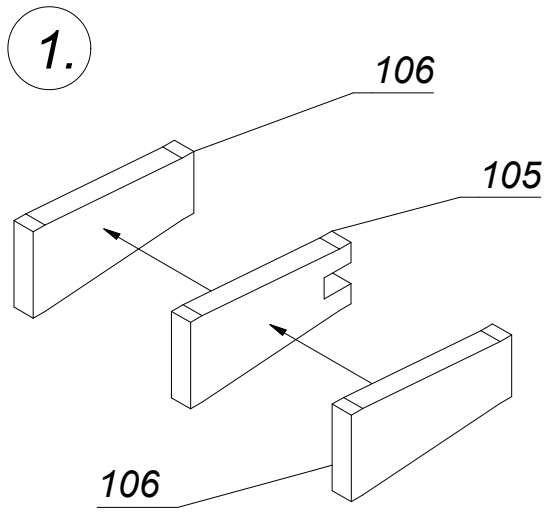

16x

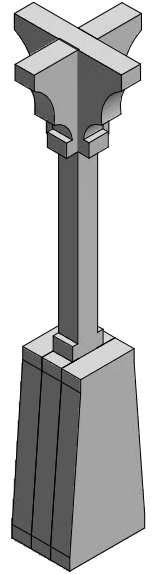
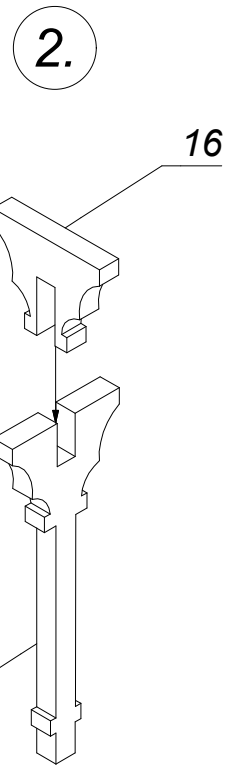

10x

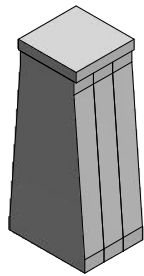
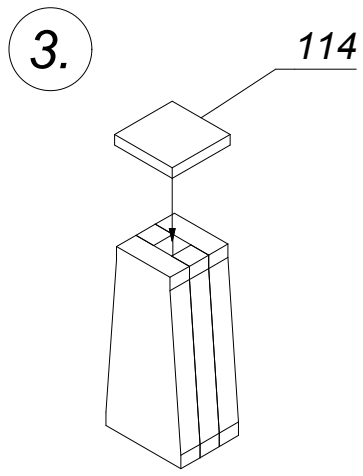

6x

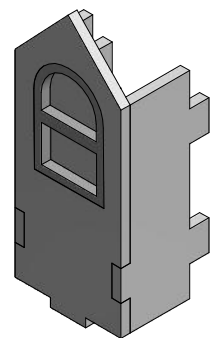
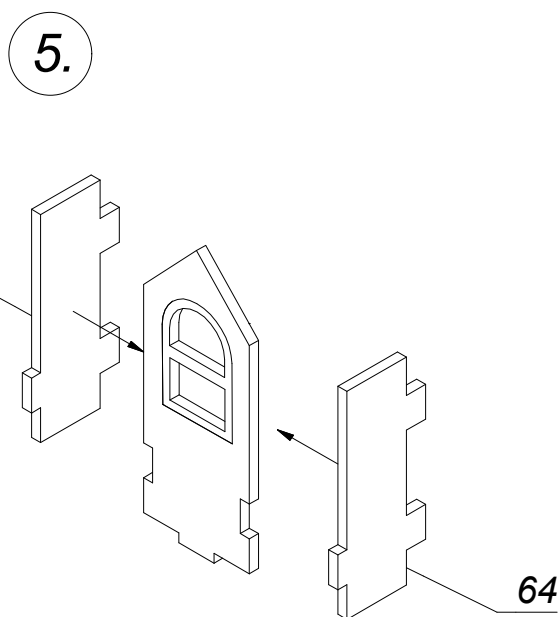
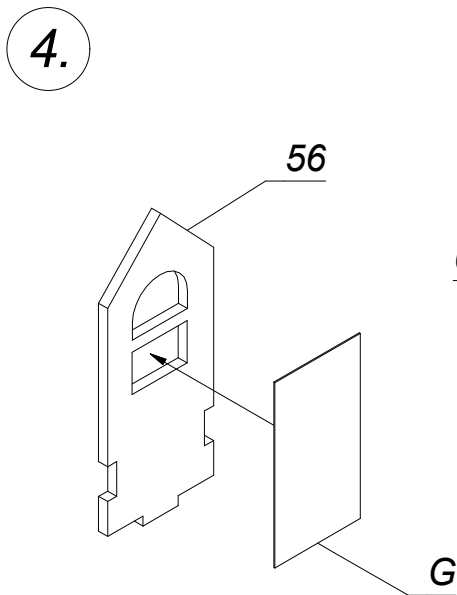
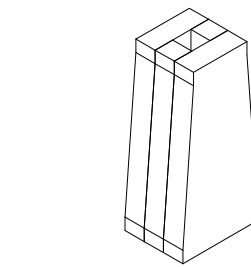

7x

6.

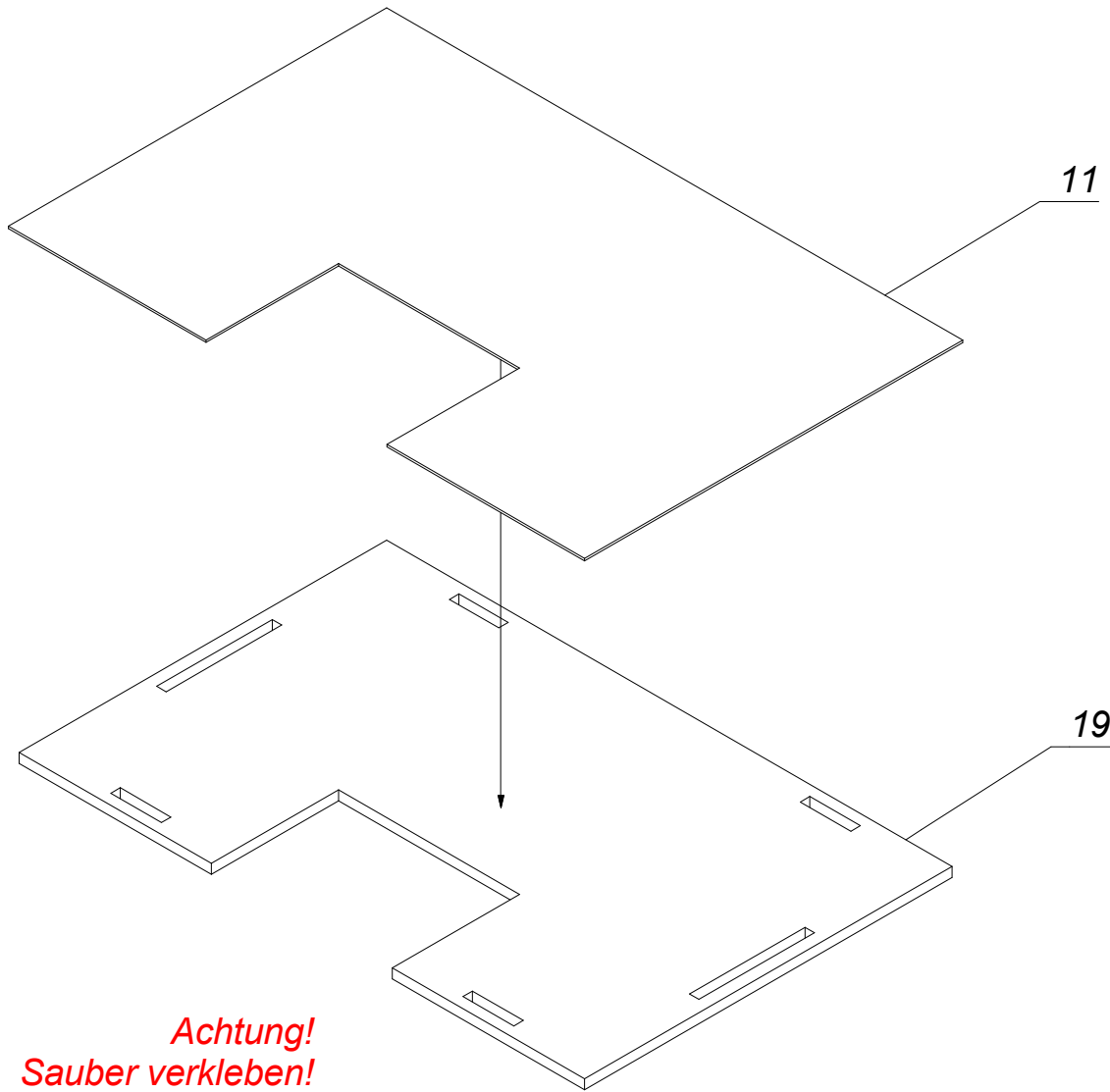

Achtung!
Sauber verkleben!
Kleberückstände entfernen!

Attention!
Glue accurately!
Remove residues of glue.

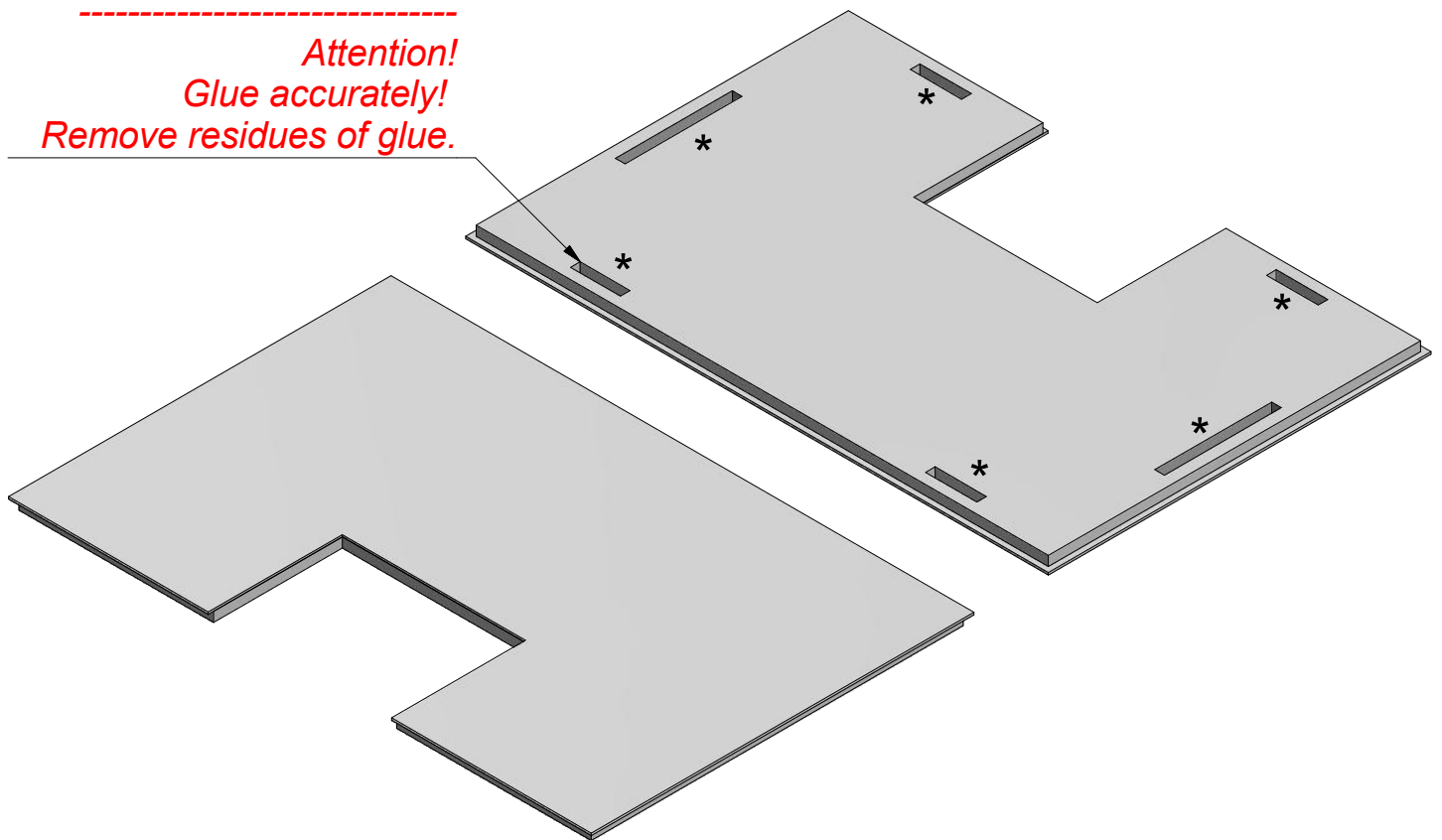

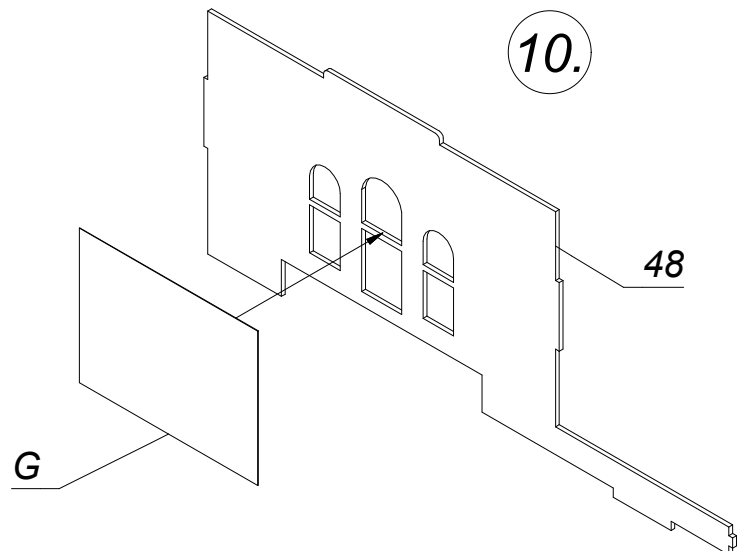
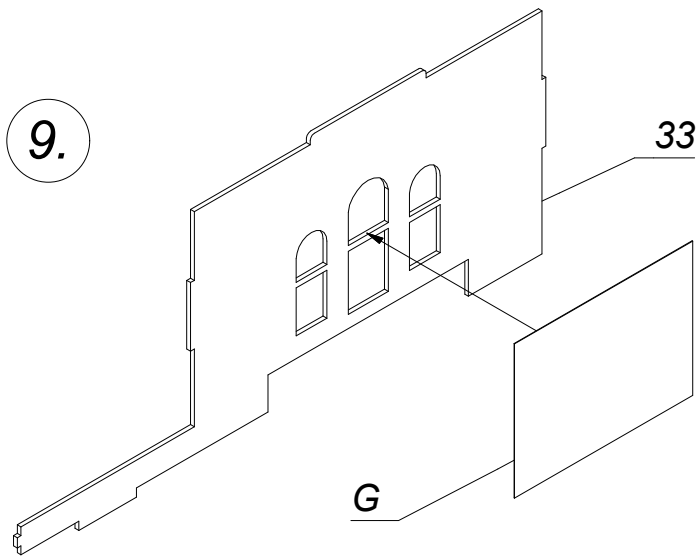
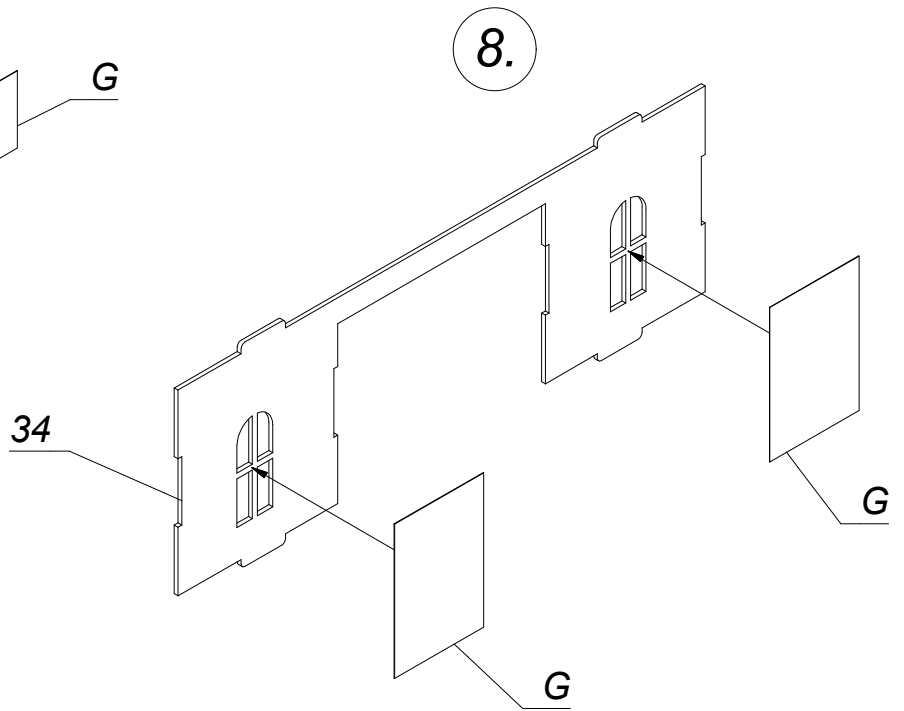
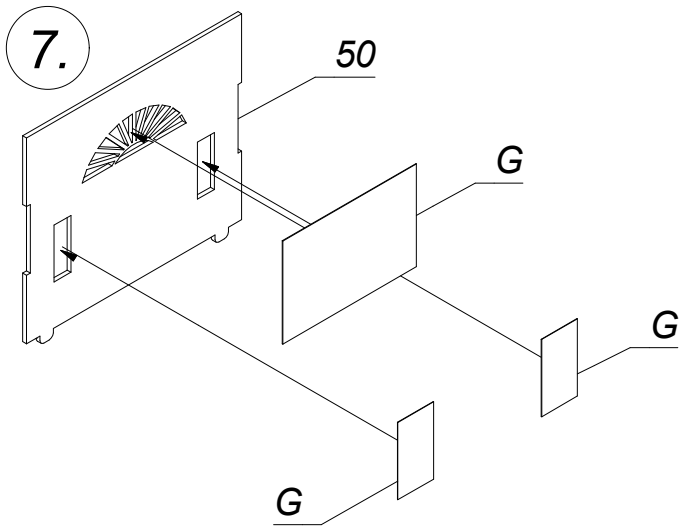

11.

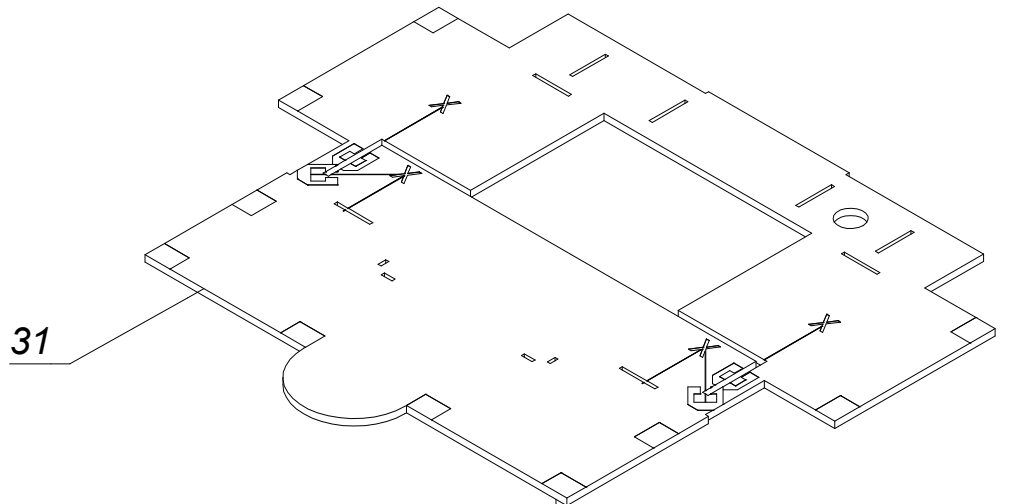
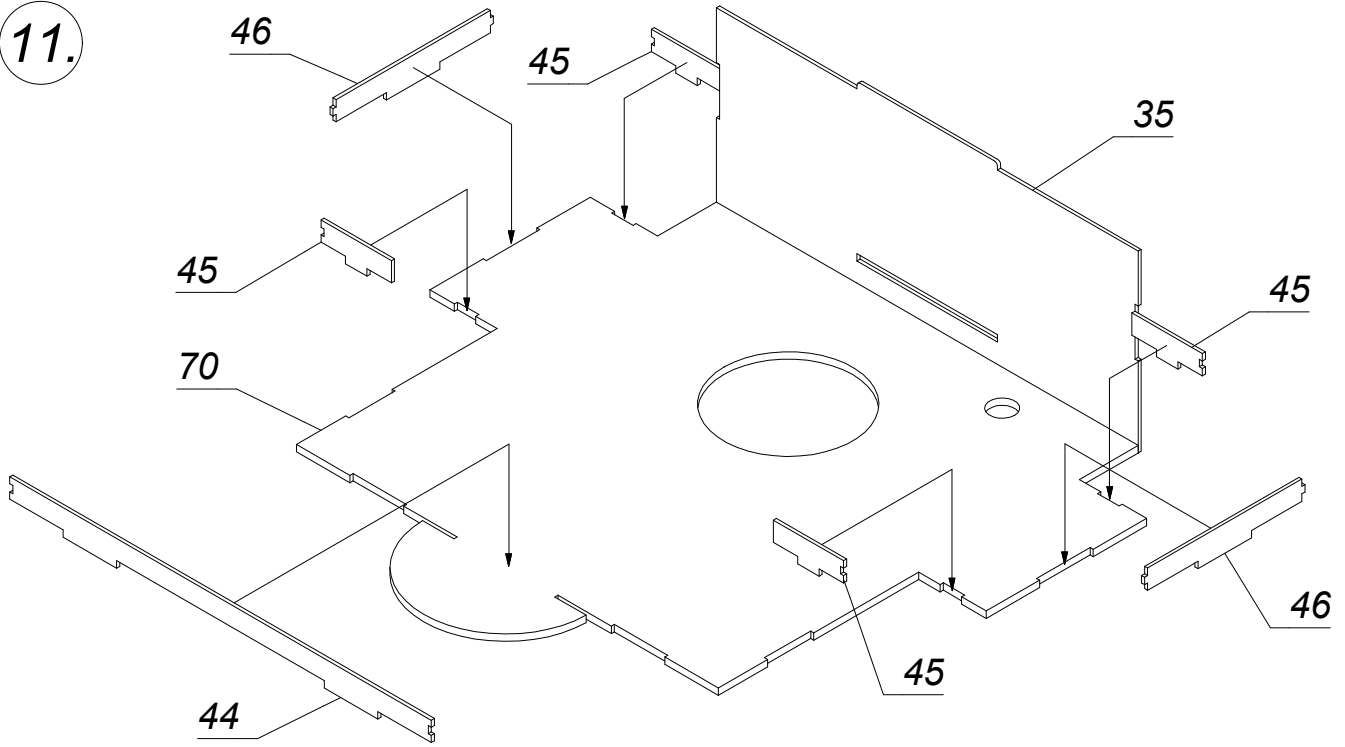

12.

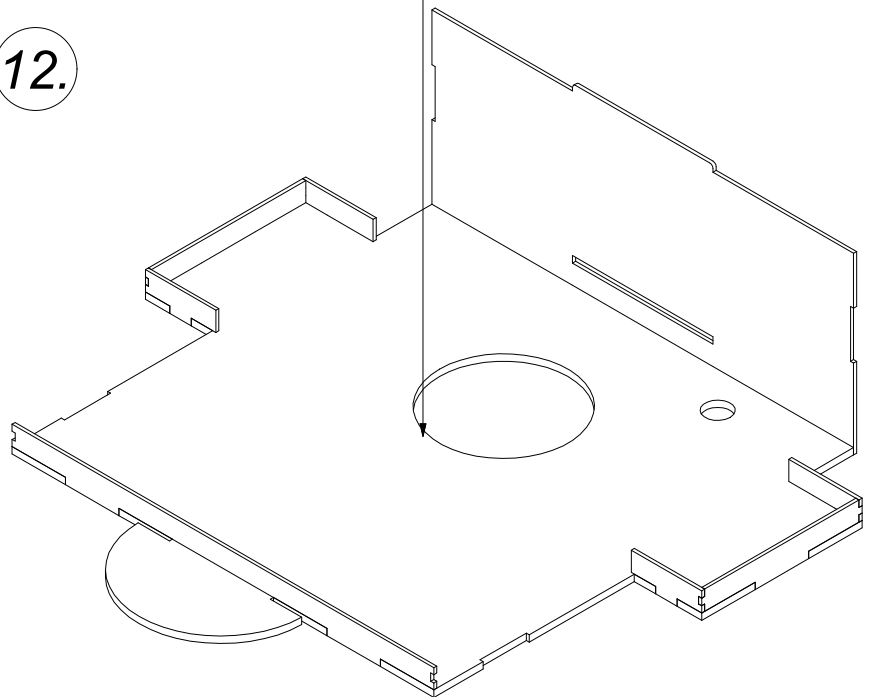

13.

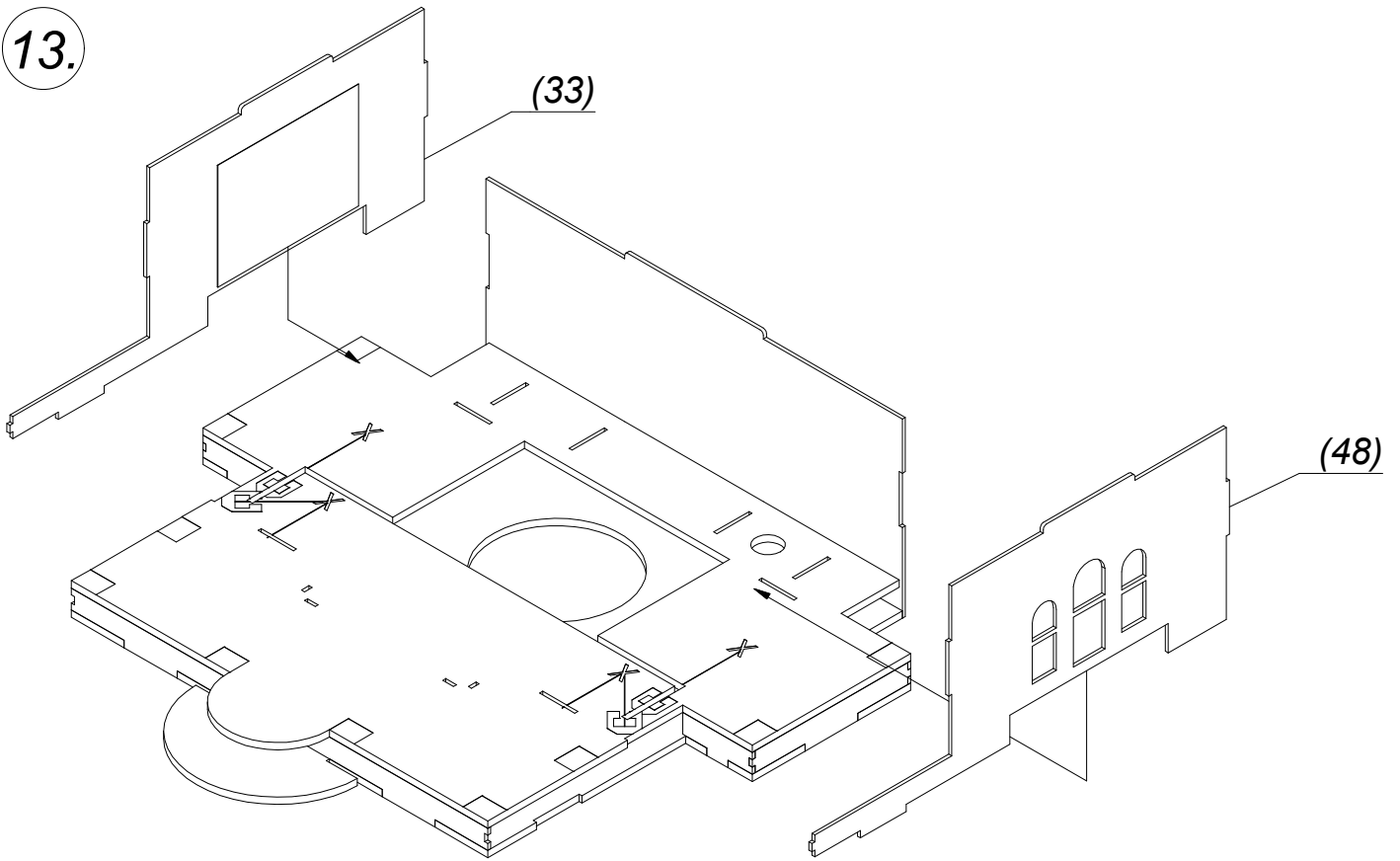

(37)

14.

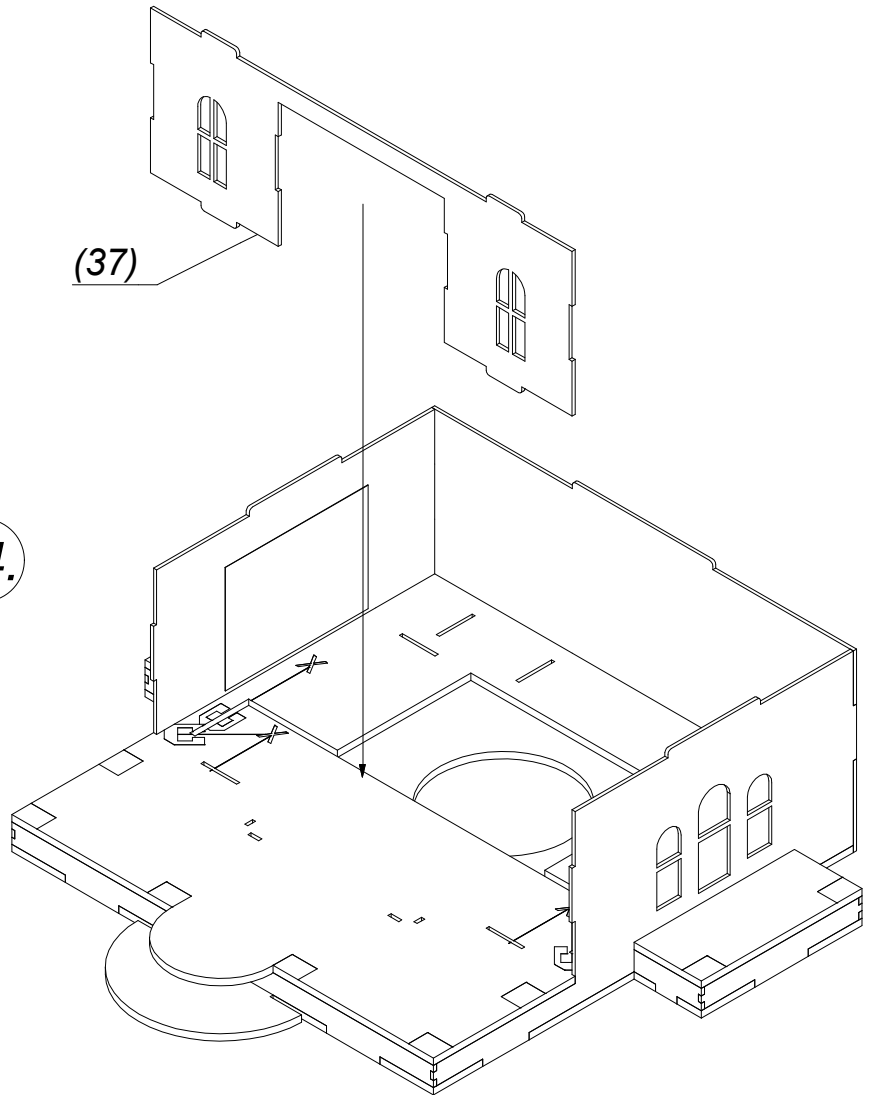

15.

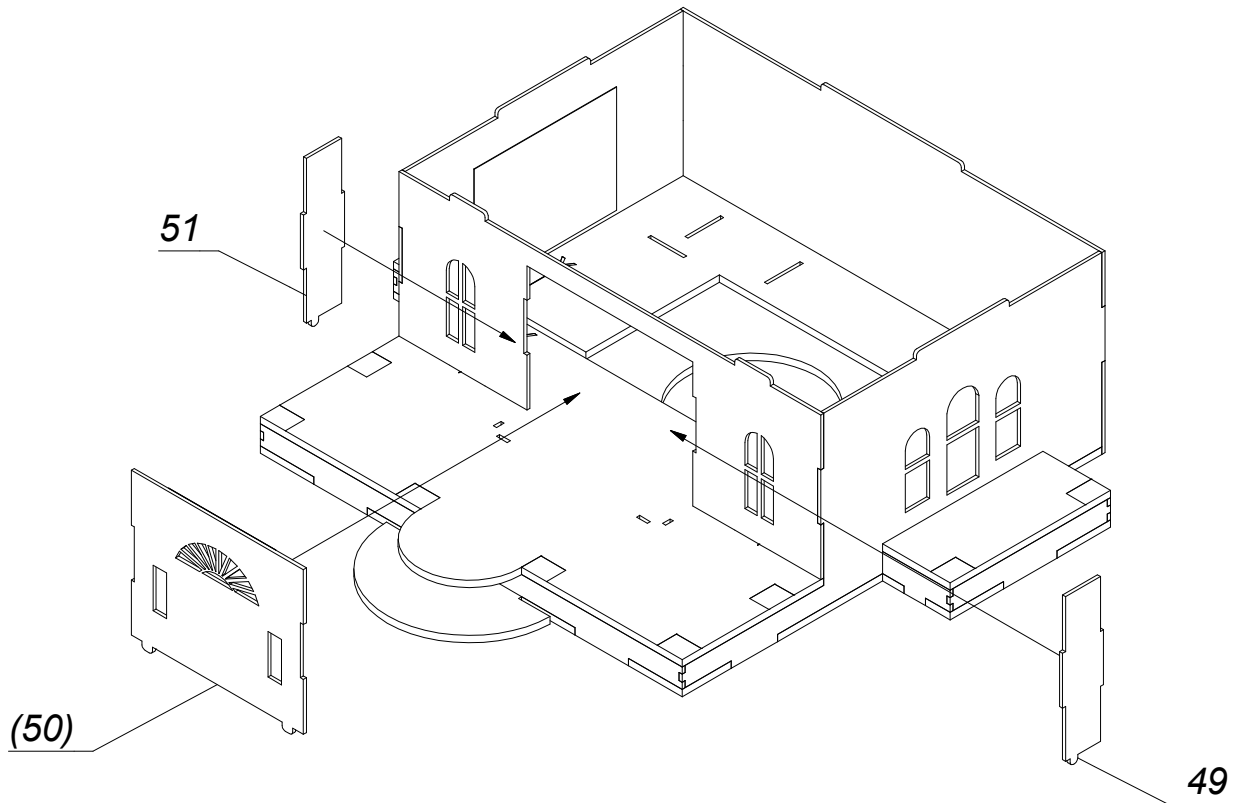

16.

Reihenfolge beachten! ----- Pay attention to correct sequence!

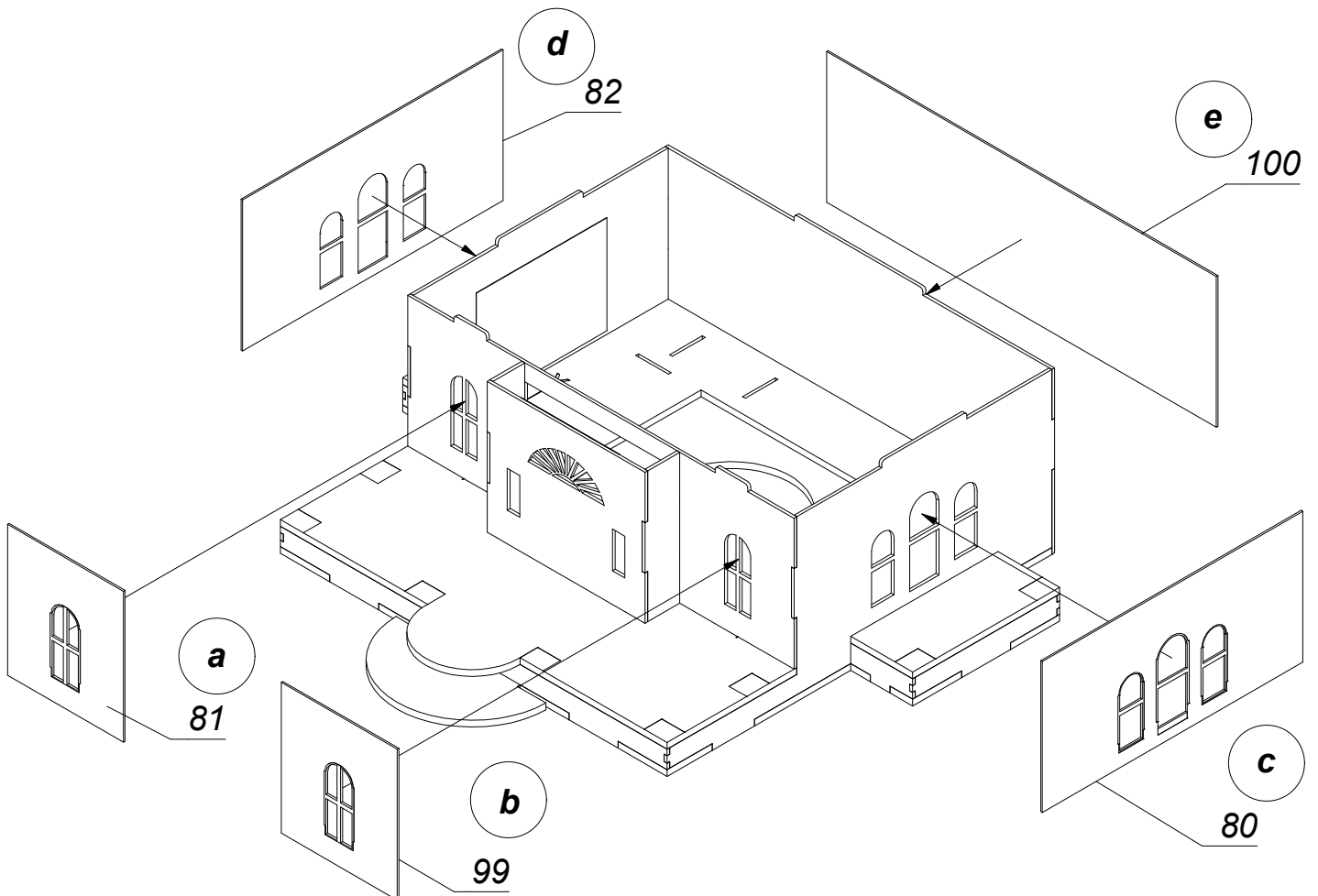

Achtung!
Teil 96 und 98 richtig ausrichten. Verdrehgefahr!
Gravur ist umlaufend.

17.

Attention!
Add parts 96 and 98 in the correct position.
Pay attention not to twist them.
Engraving is circumferential.

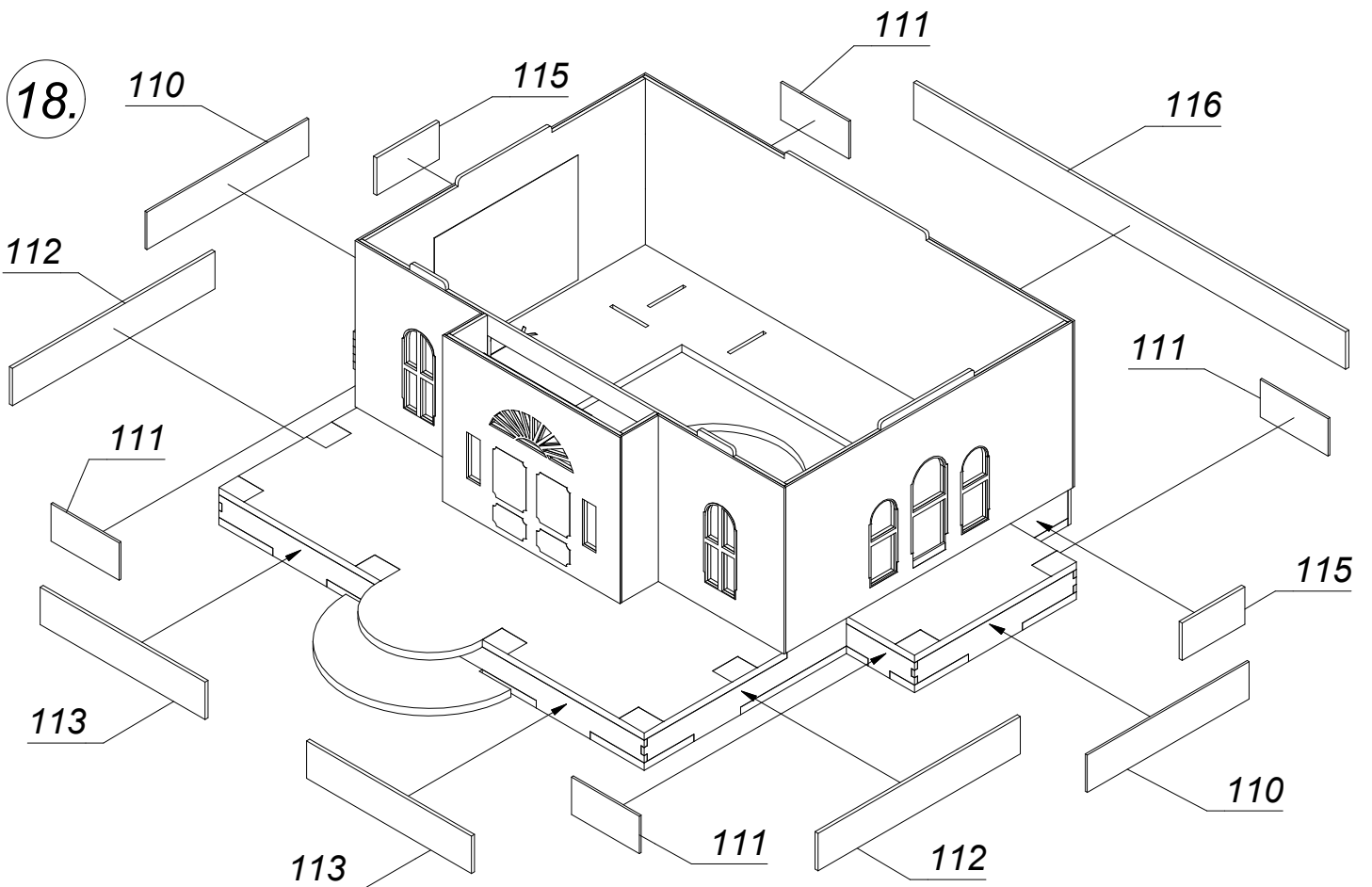
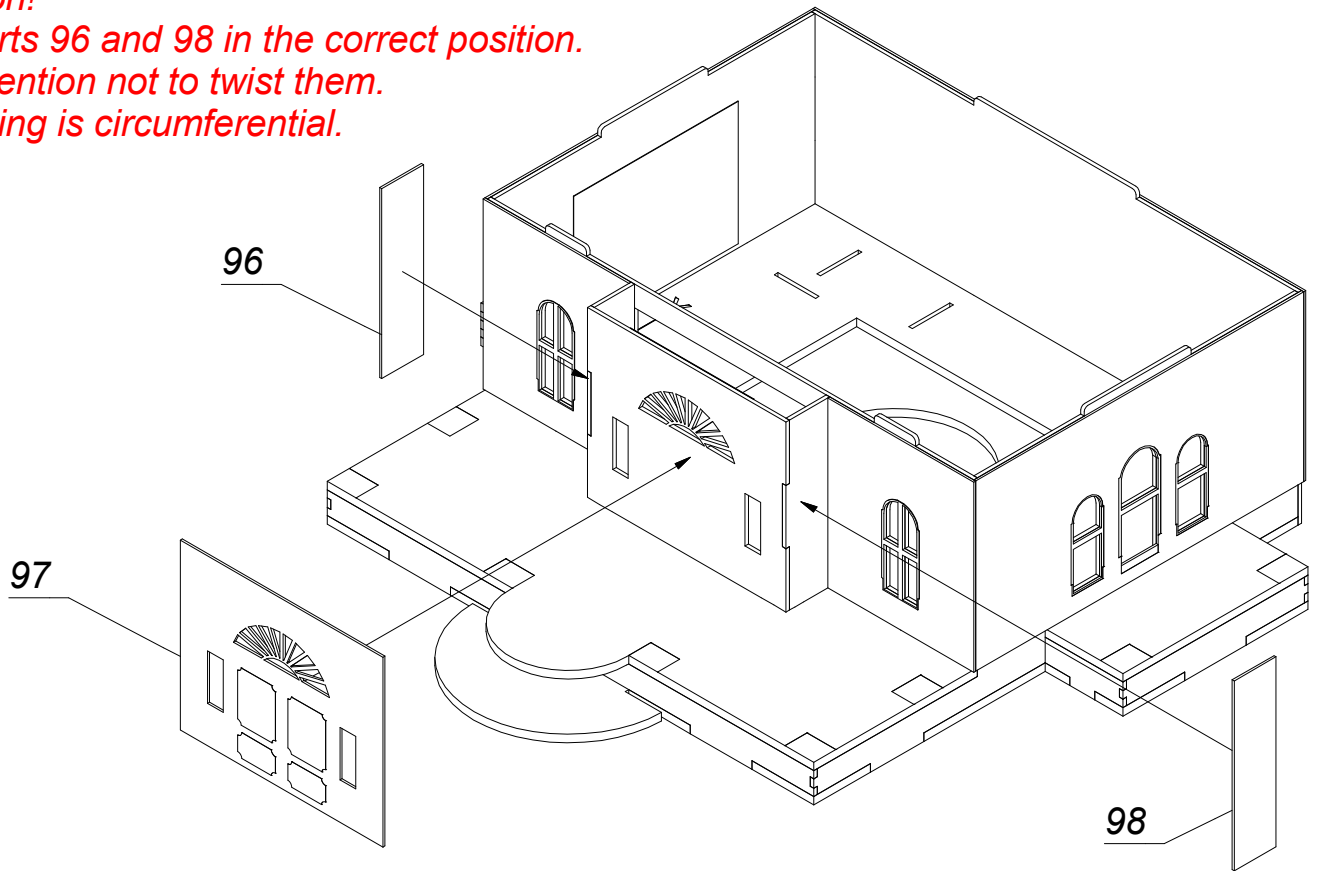

19.

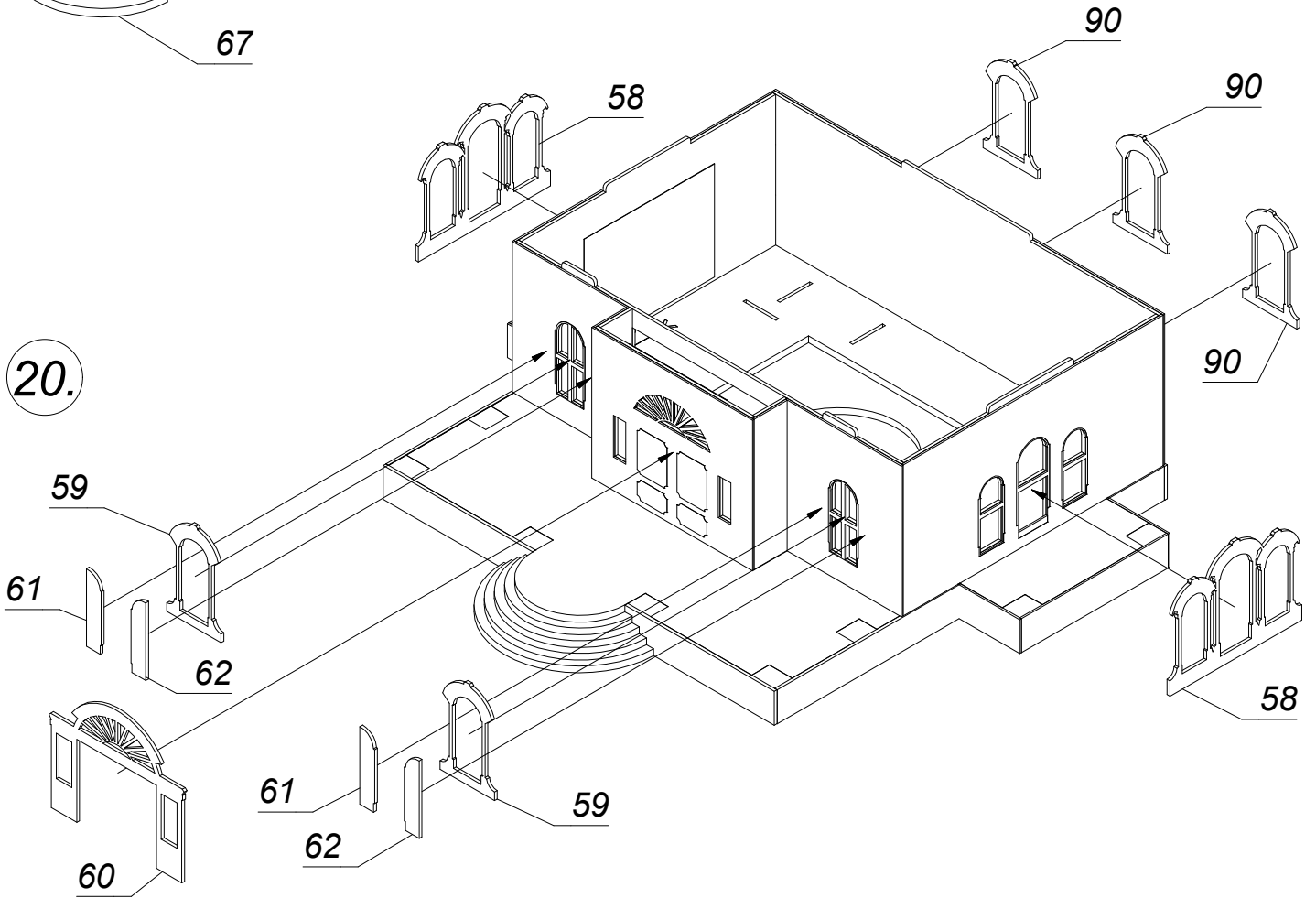
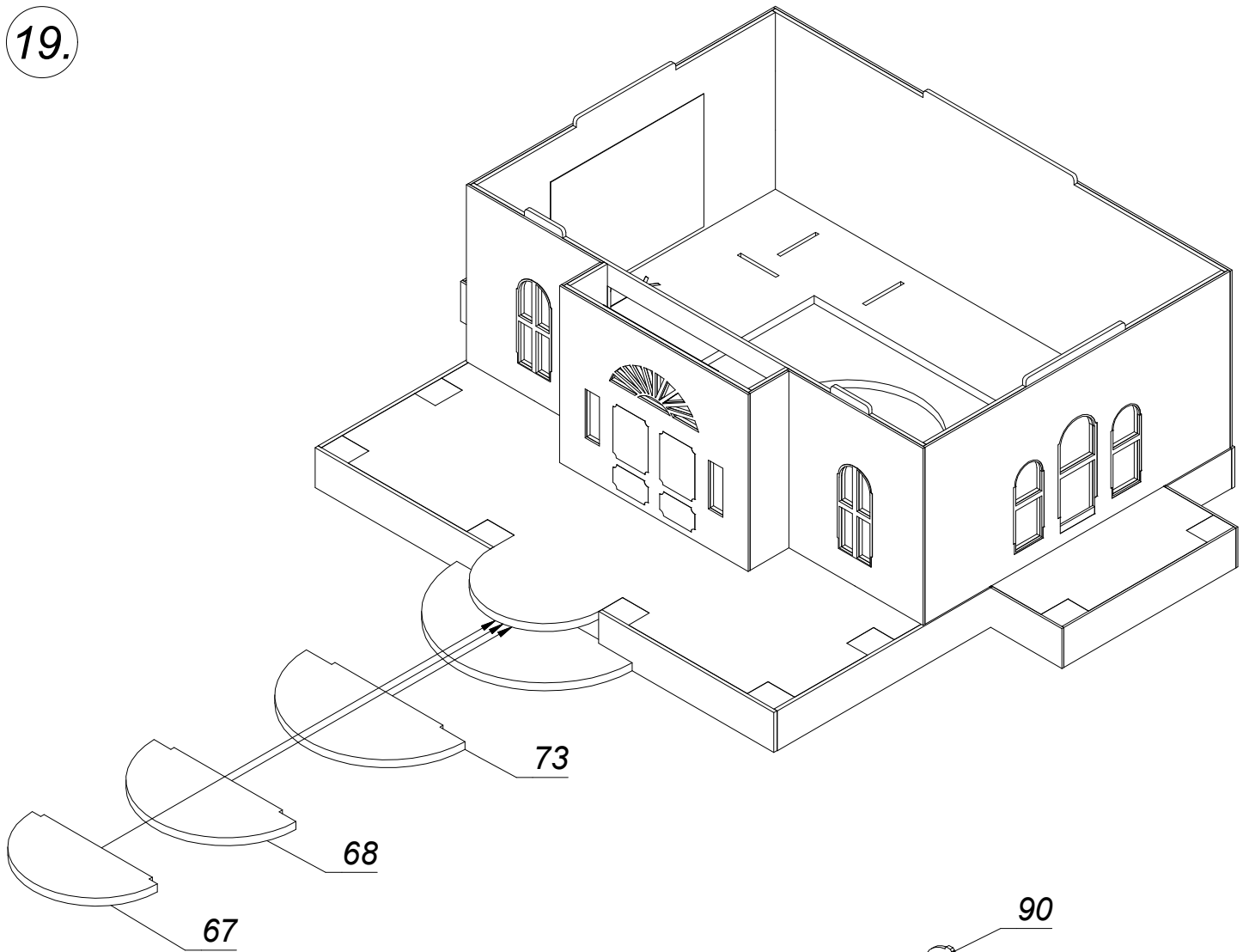

21.

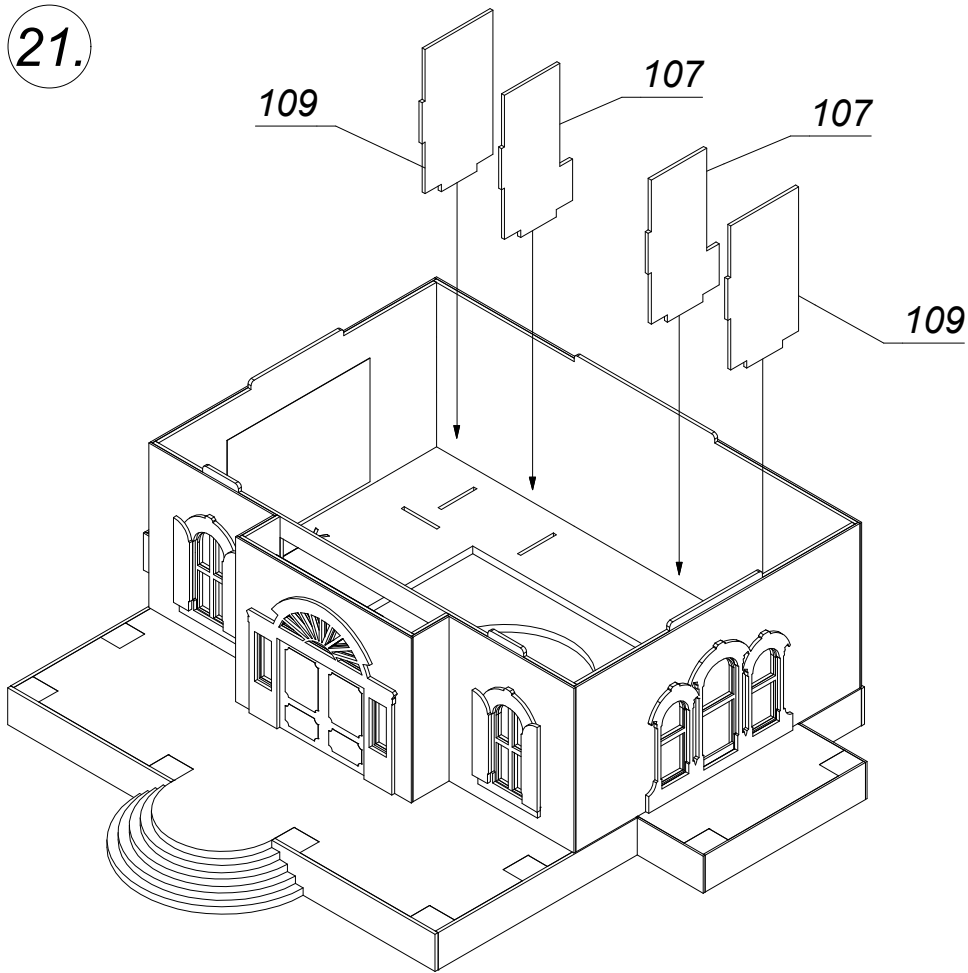

22.

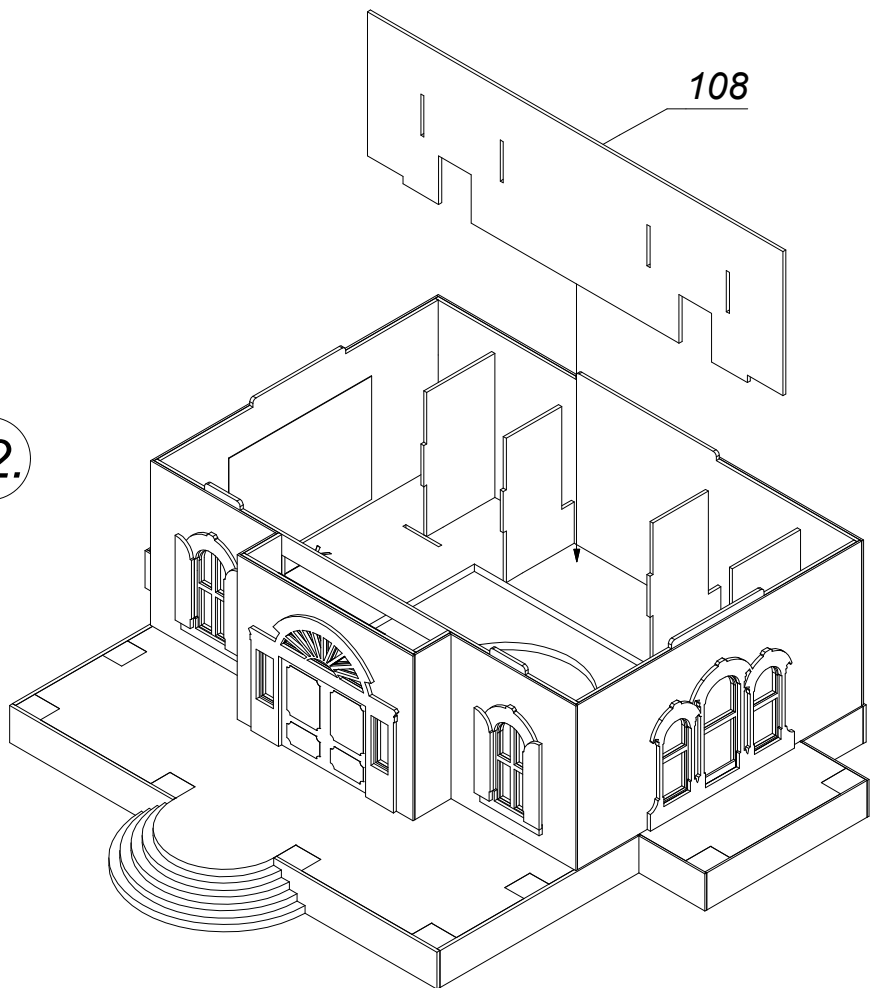

23.

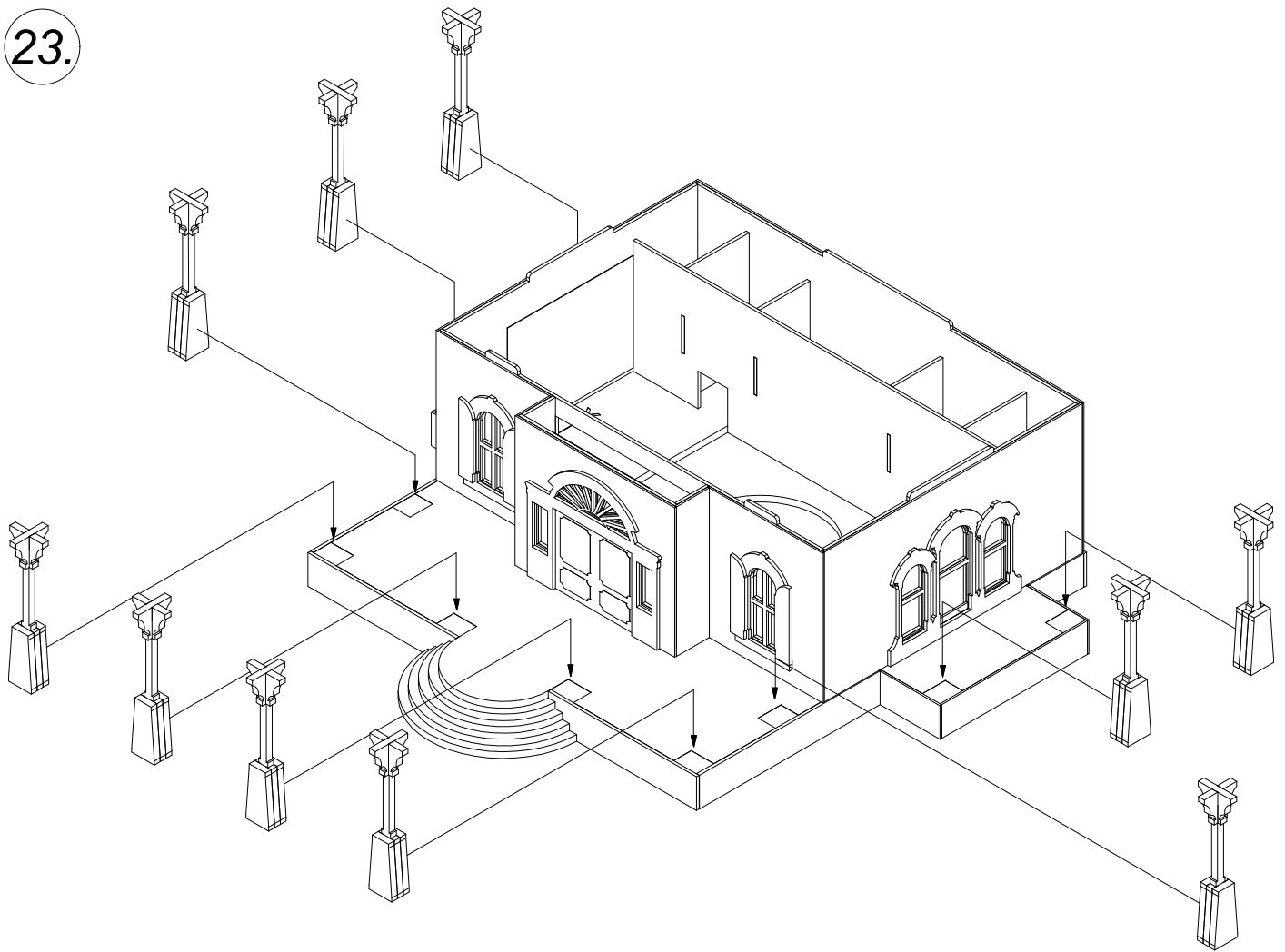

24.

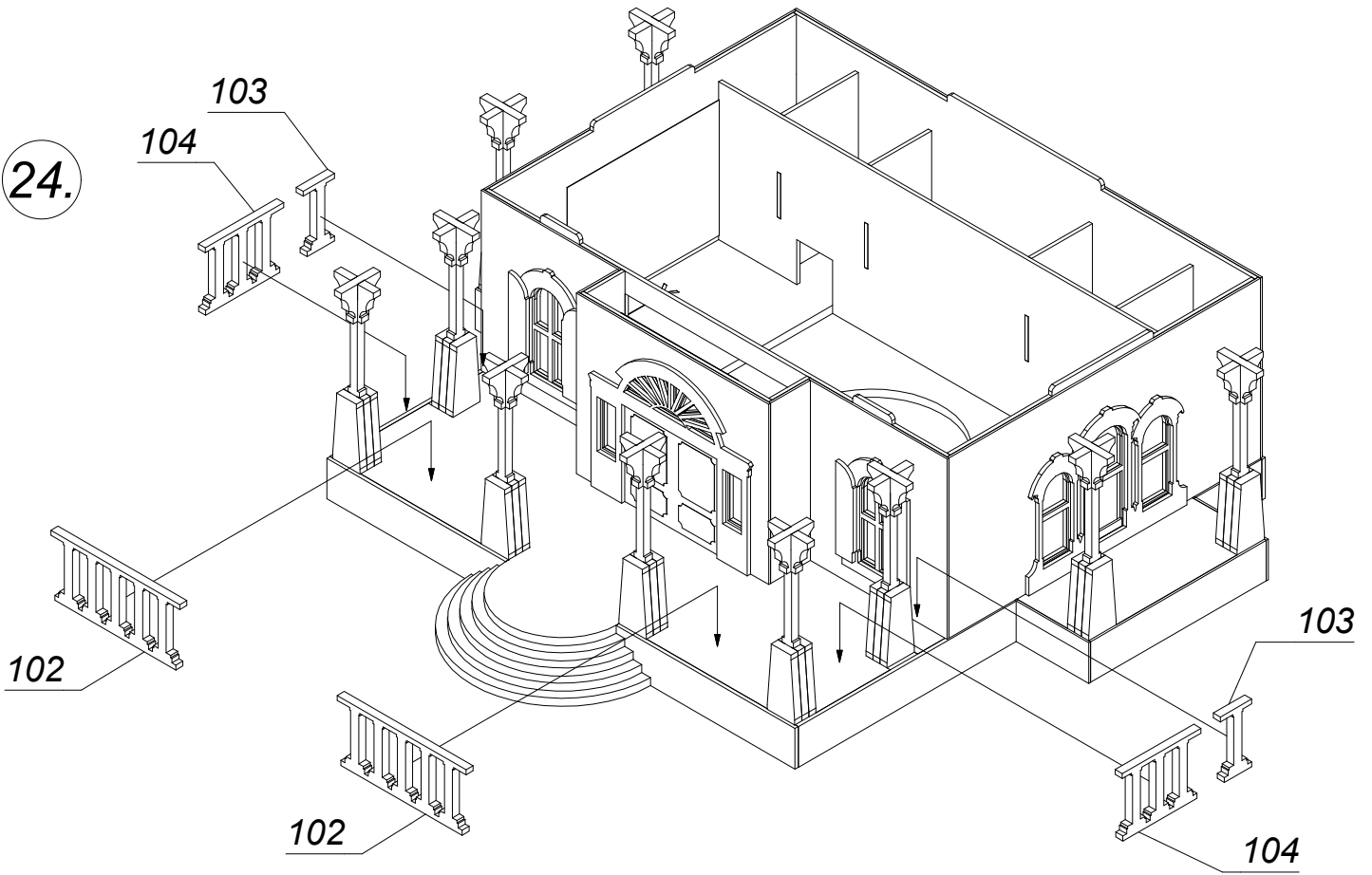

25.

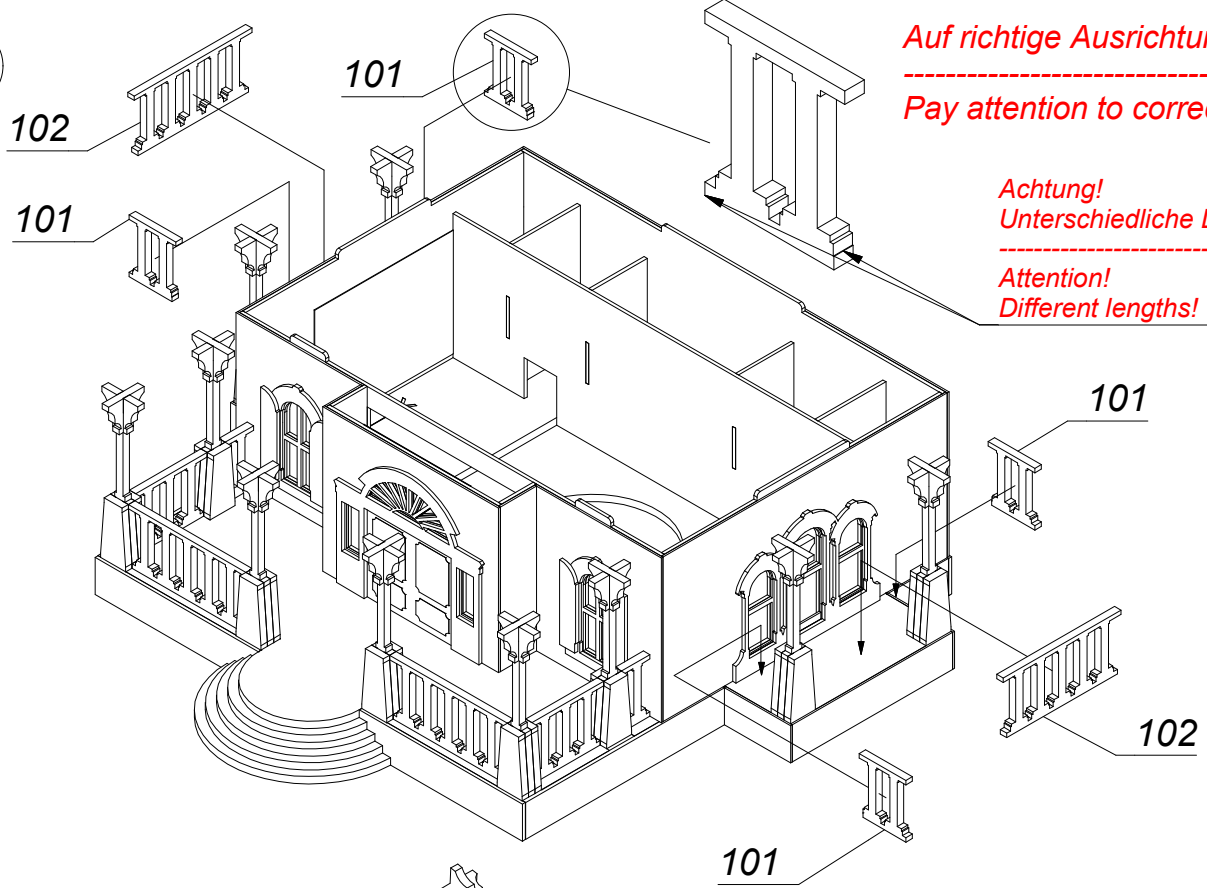

Auf richtige Ausrichtung achten!

Pay attention to correct position!

Achtung!
Unterschiedliche Längen!

Attention!
Different lengths!

26.

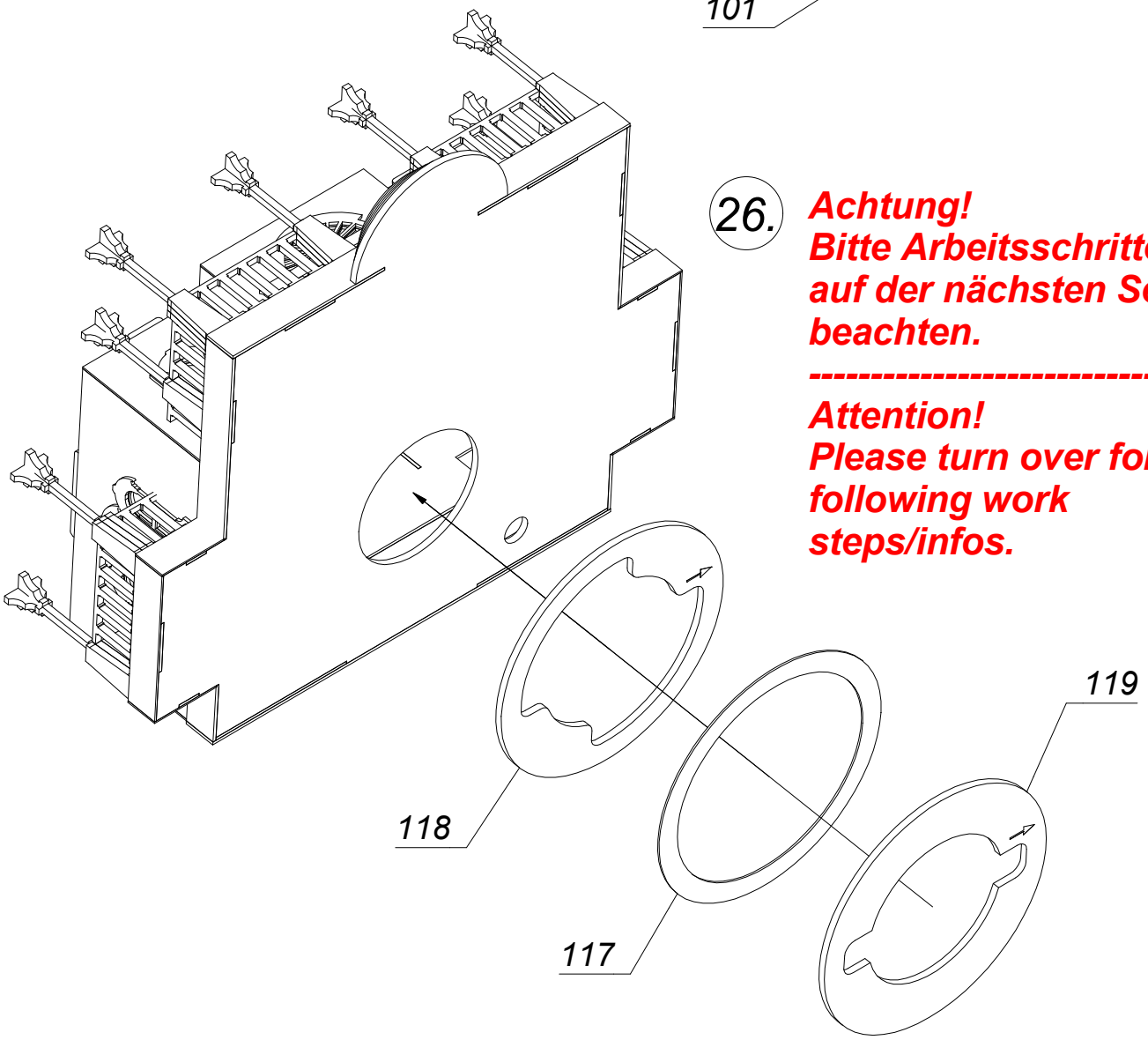

Achtung!
Bitte Arbeitsschritte/Infos
auf der nächsten Seite
beachten.

Attention!
Please turn over for
following work
steps/infos.

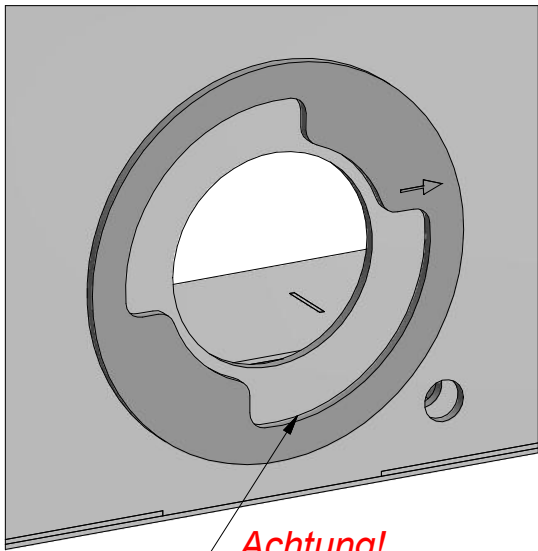

27.

Achtung!
Kleberückstände entfernen!

Attention!
Remove residues of glue!

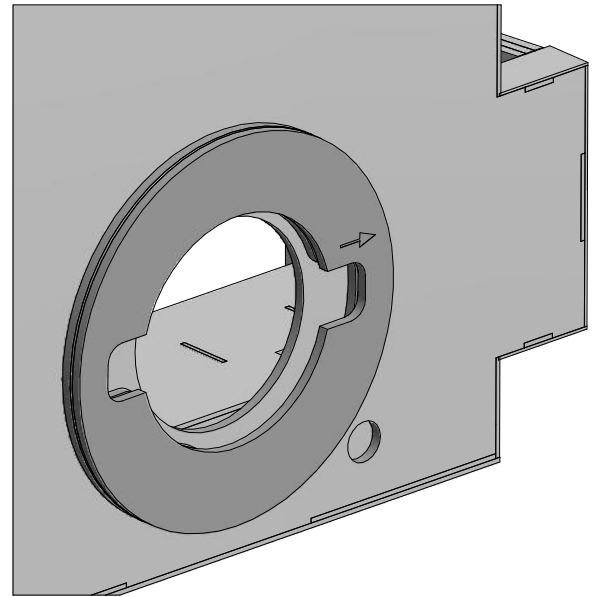

28.

Pfeilrichtung = Kabelausgang

direction of arrow = cable outlet

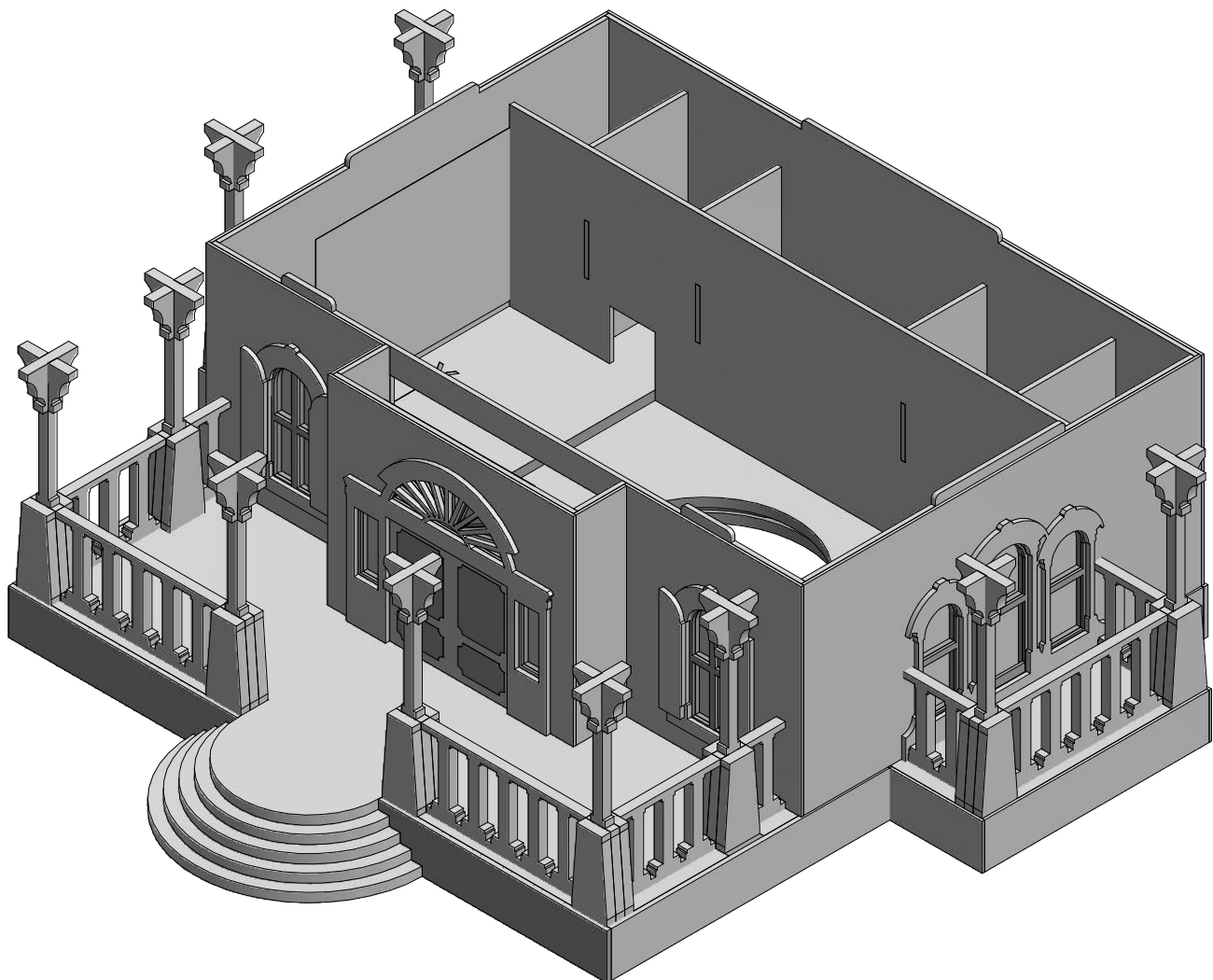

29.

2x

36 / 42

G

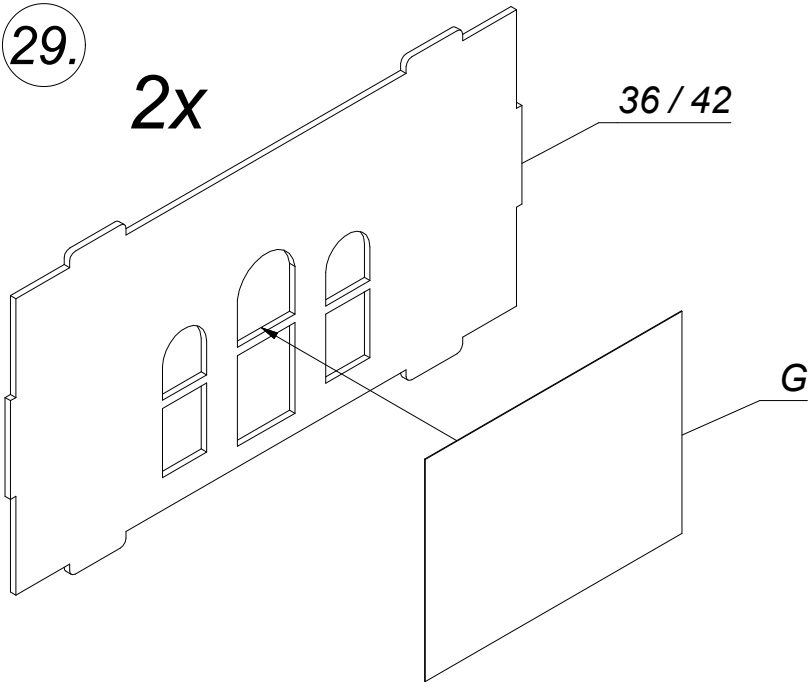

30.

37

G

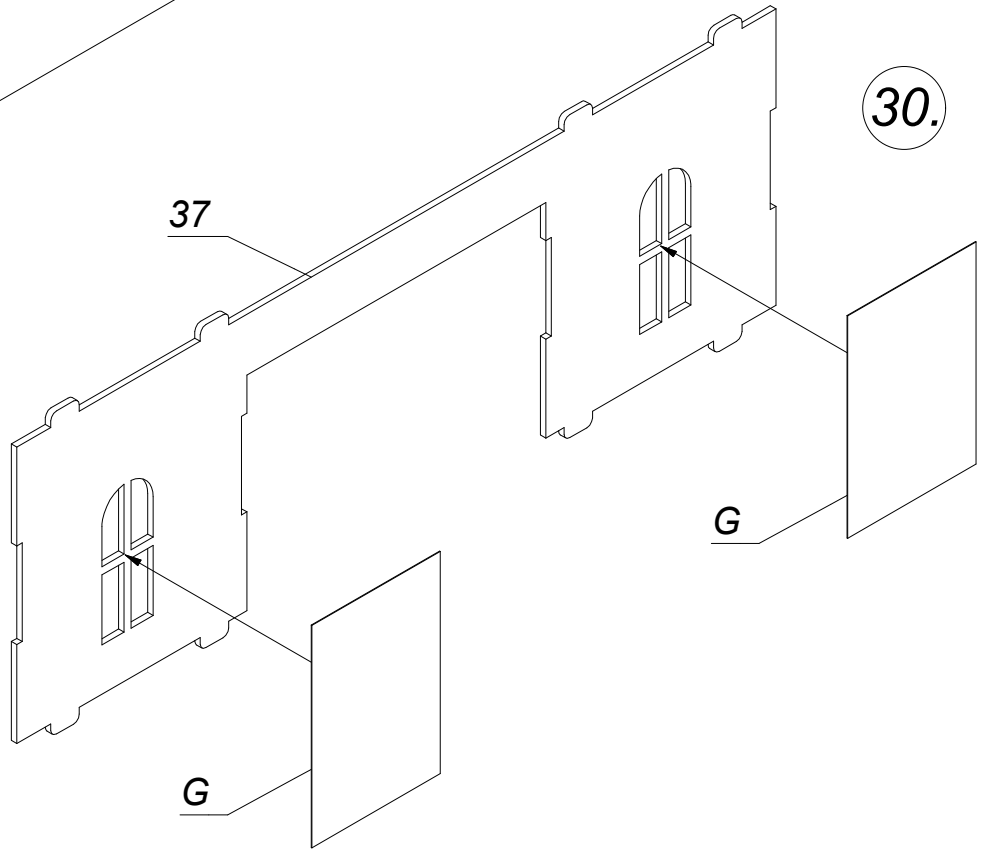

31.

39

G

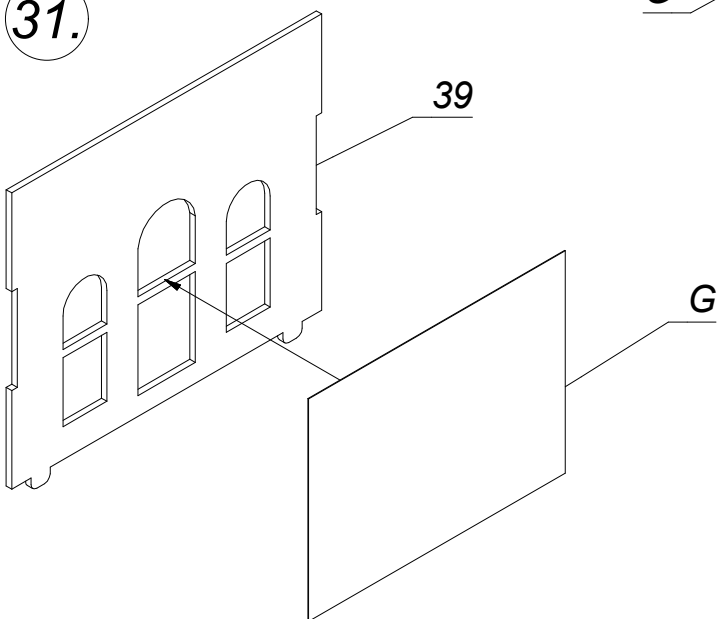

32.

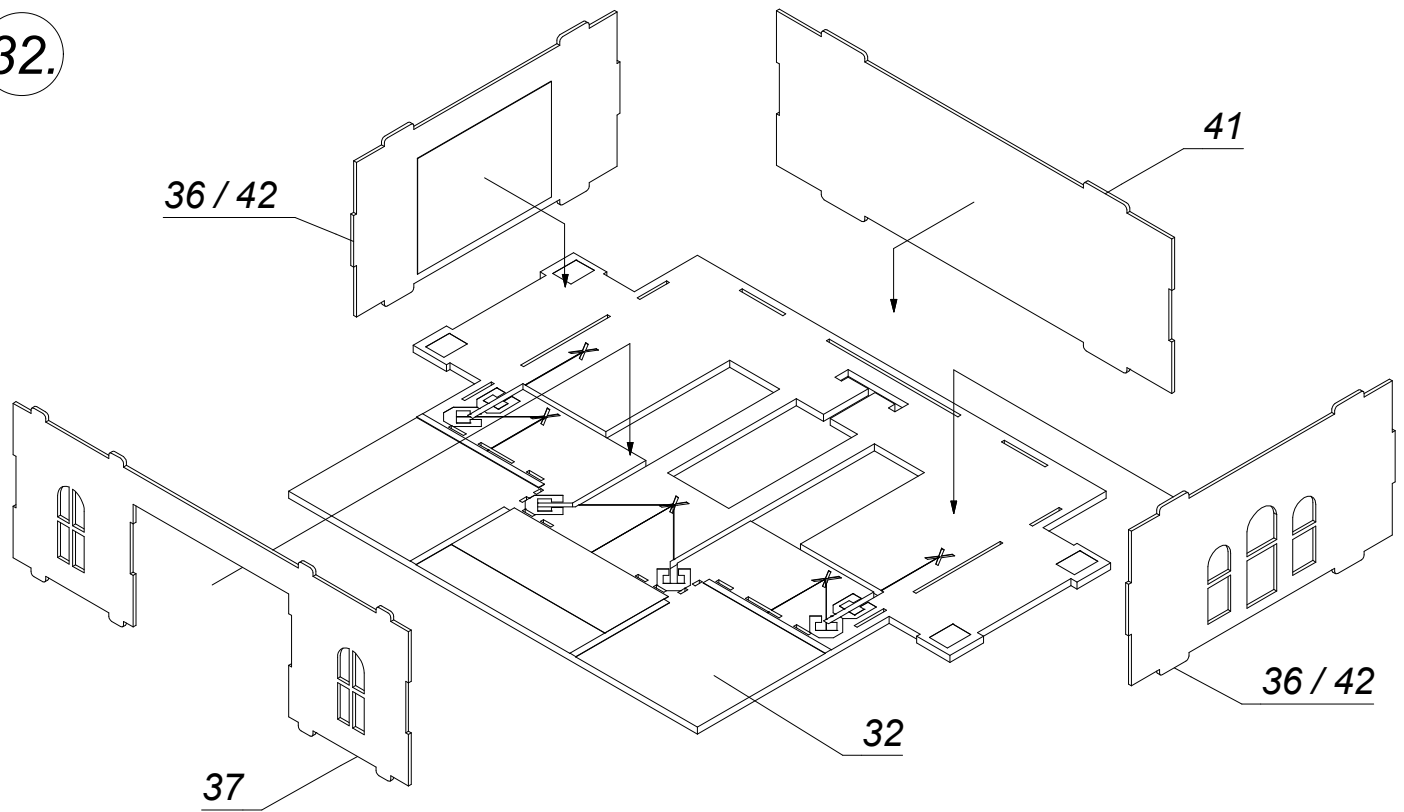

33.

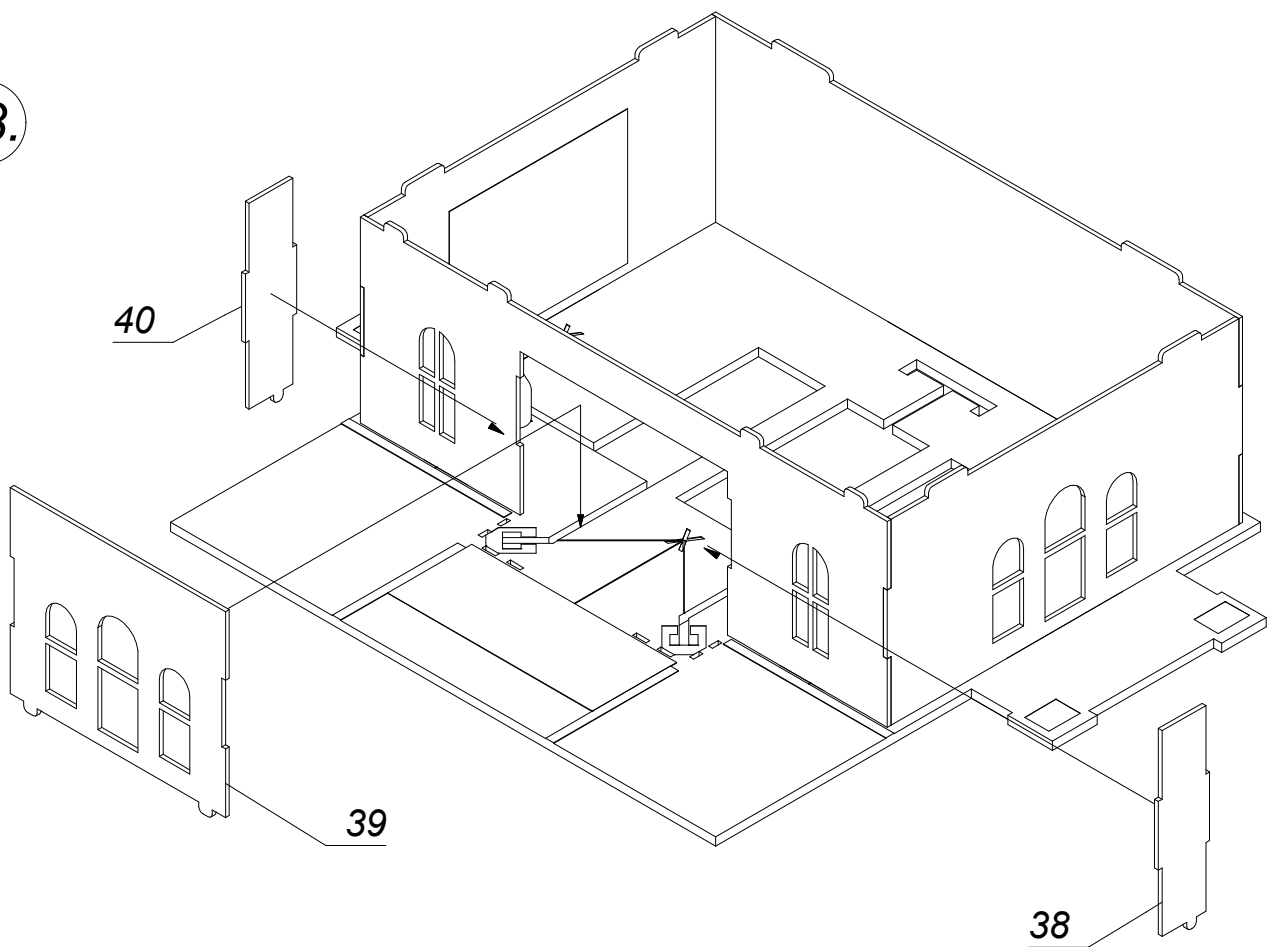

34.

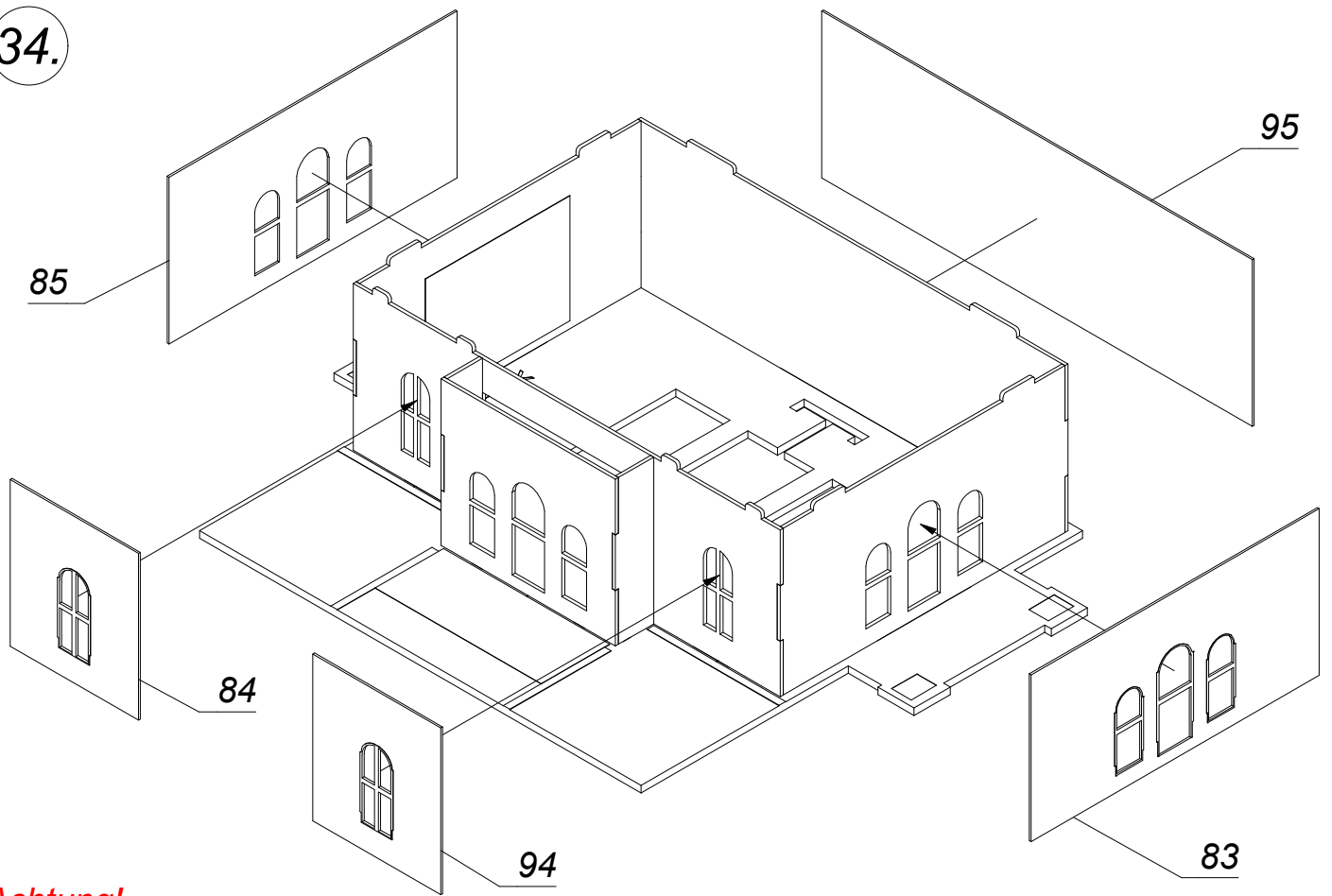

Achtung!
Teil 91 und 93 richtig ausrichten. Verdrehgefahr!
Gravur ist umlaufend.

Attention!
Add parts 91 and 93 in the correct position.
Pay attention not to twist them.
Engraving is circumferential.

35.

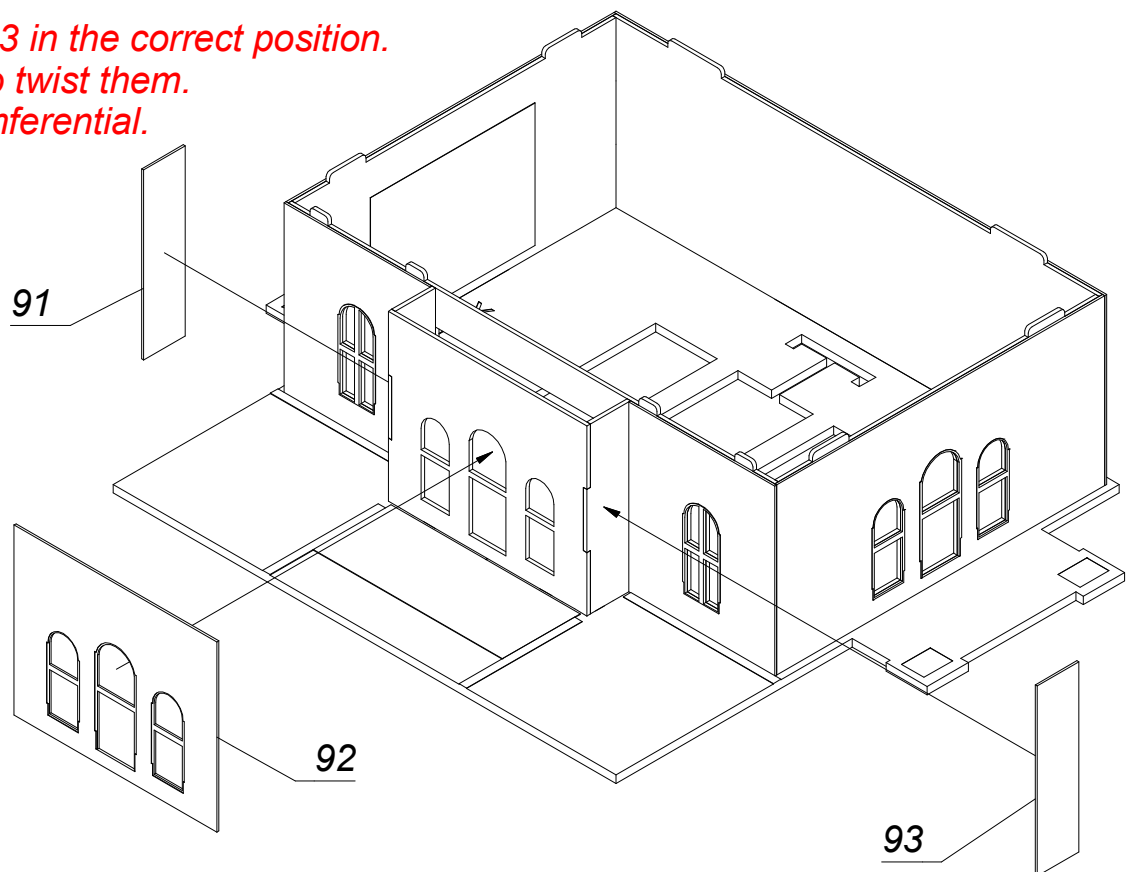

36.

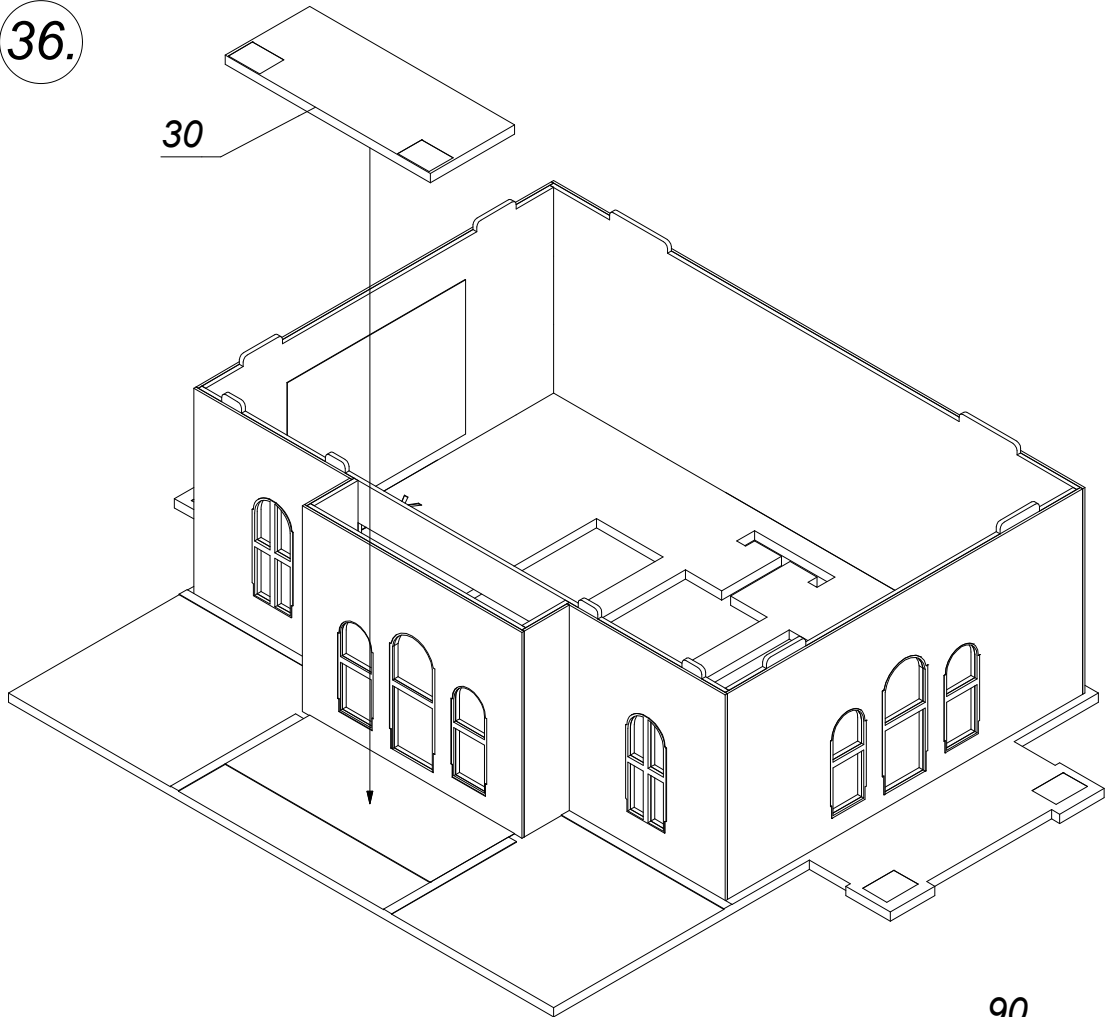

37.

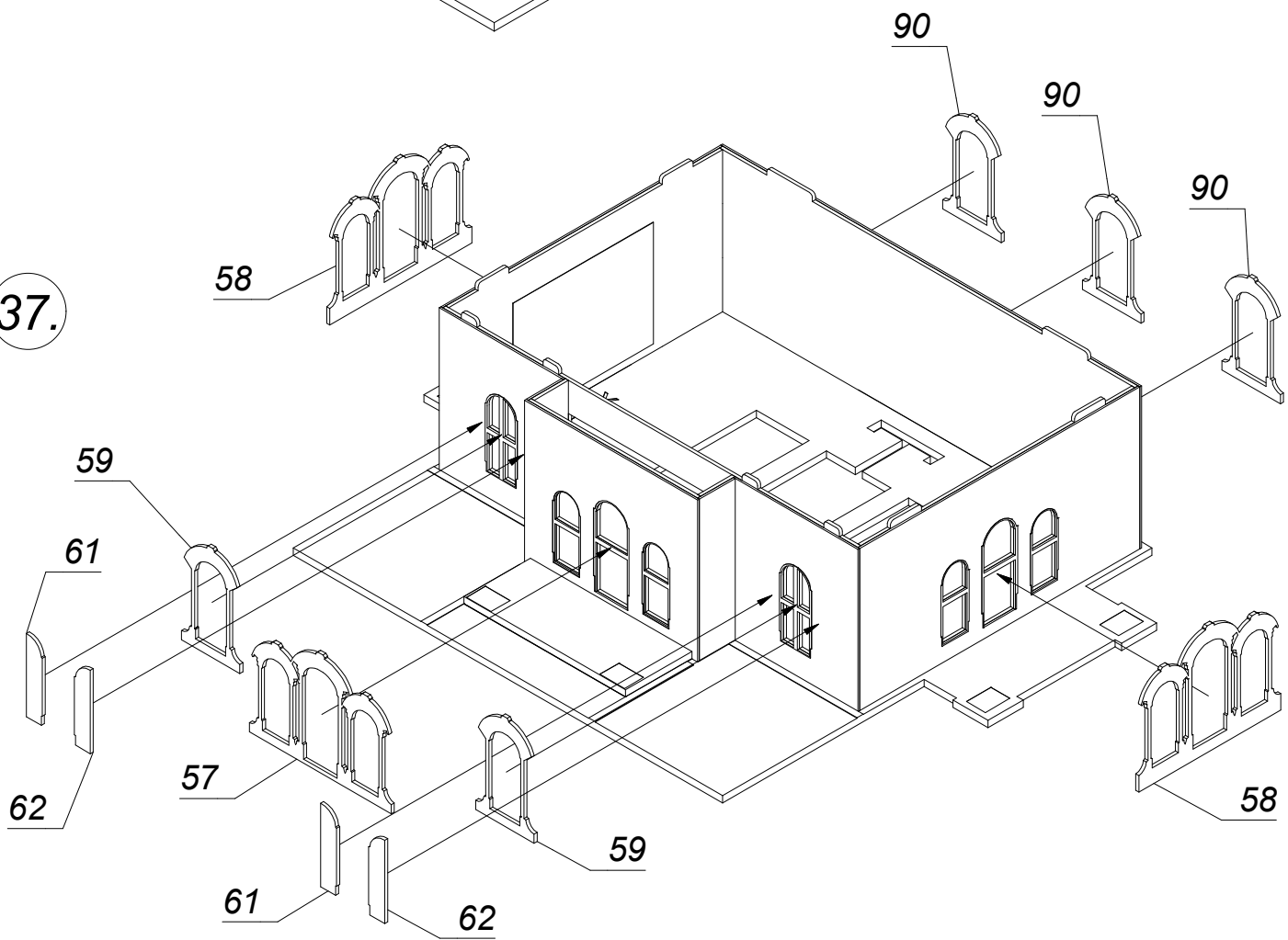

38.

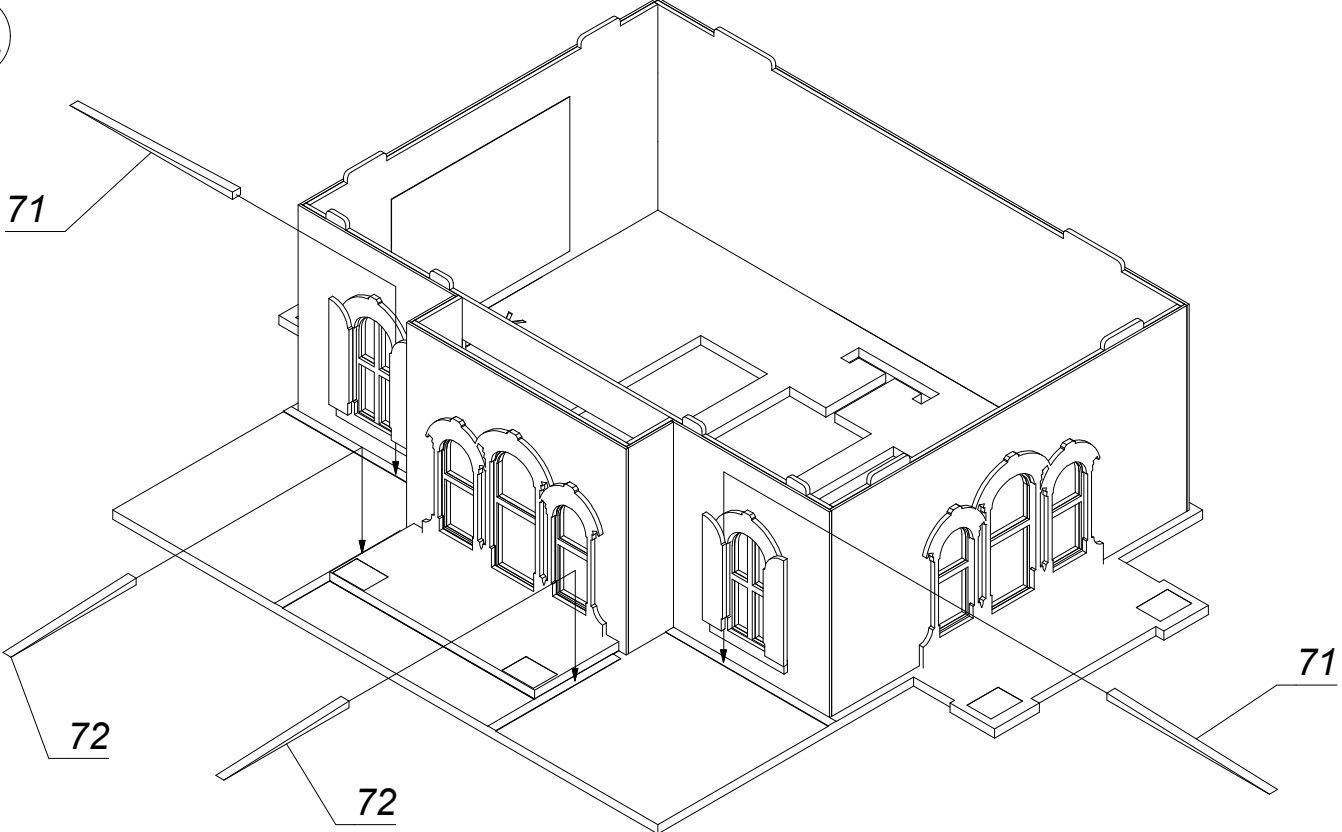

39.

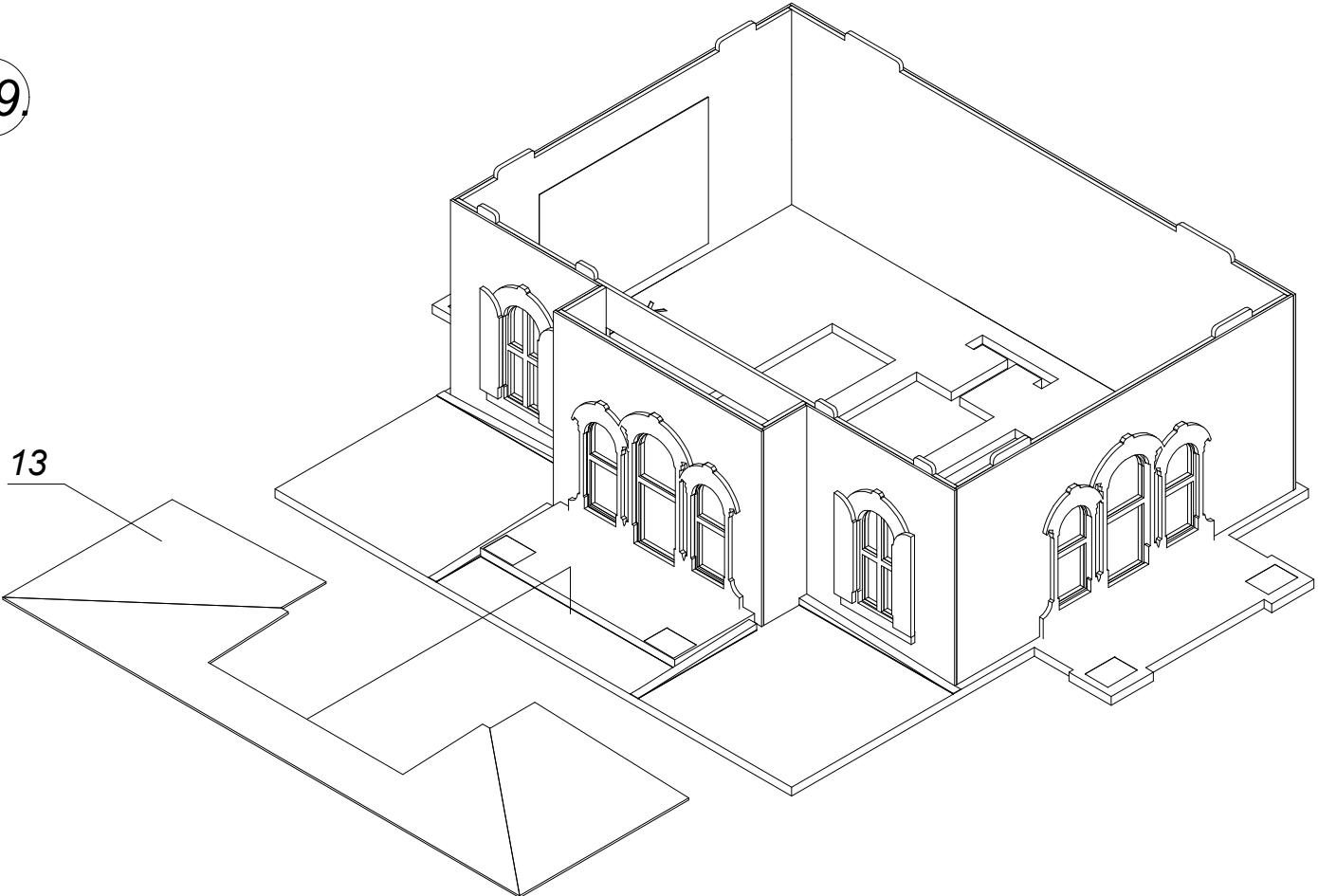

40.

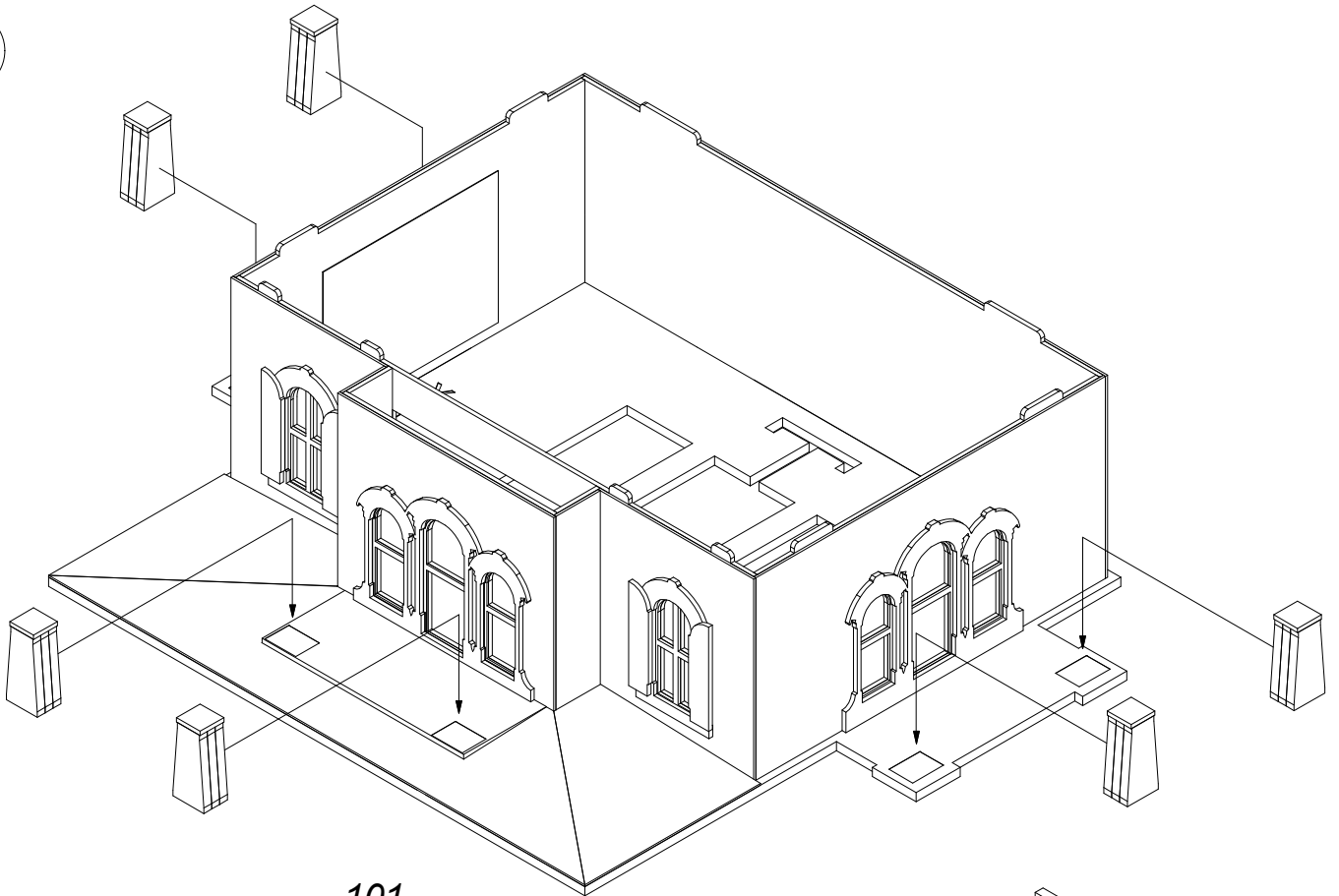

41.

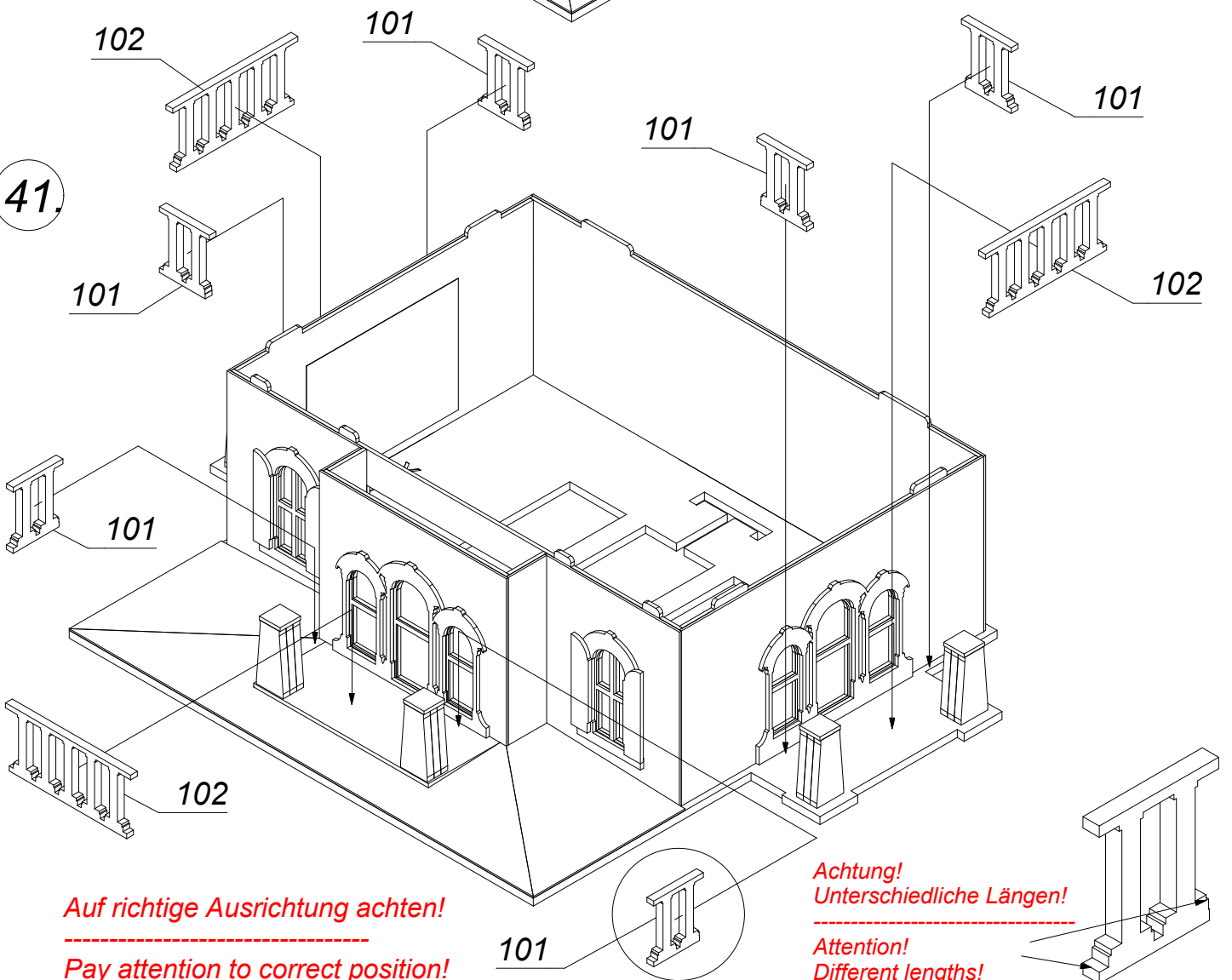

Auf richtige Ausrichtung achten!

Pay attention to correct position!

**Achtung!
Unterschiedliche Längen!**

**Attention!
Different lengths!**

101

Rechts gezeichnet / links spiegelbildlich.

Right-hand drawn / left-hand inversely.

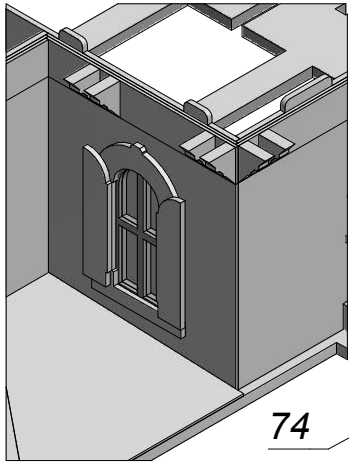

Achtung!
Teile 78 richtig ausrichten. Verdrehgefahr!

Attention!
Add parts 78 in the correct position.
Pay attention not to twist them.

42.

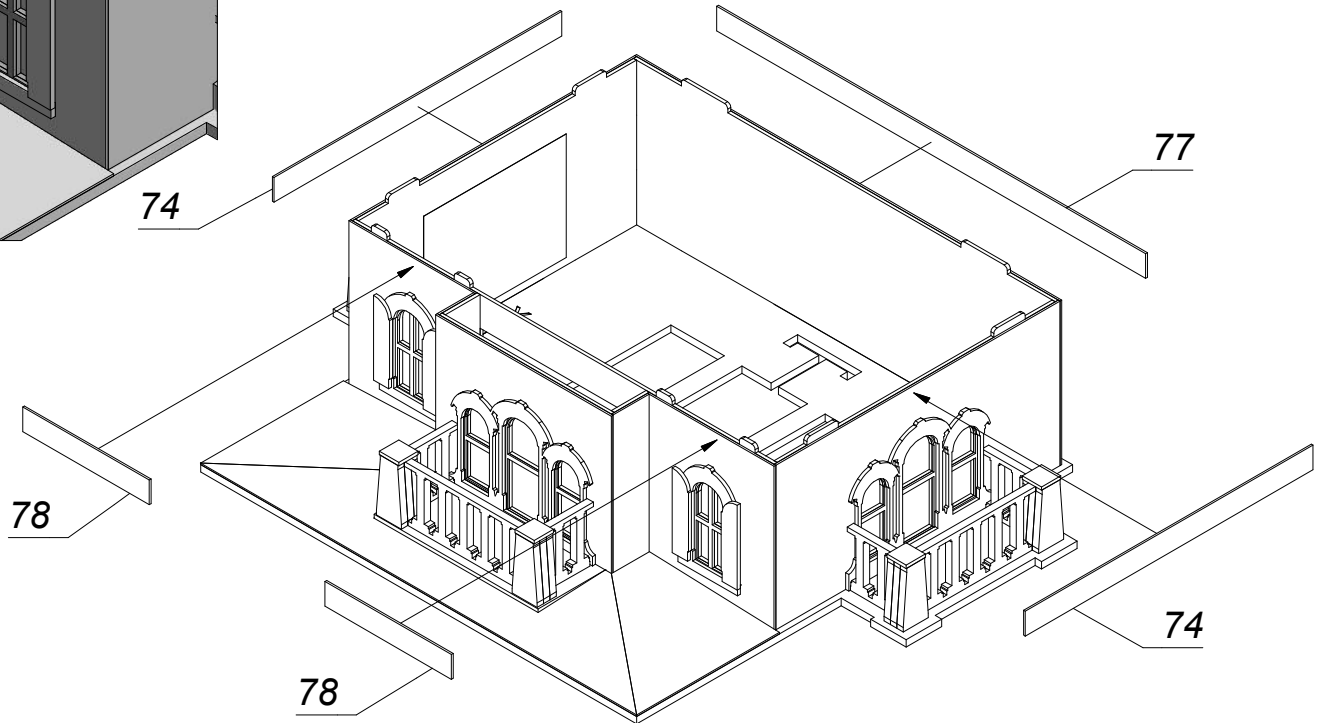

43.

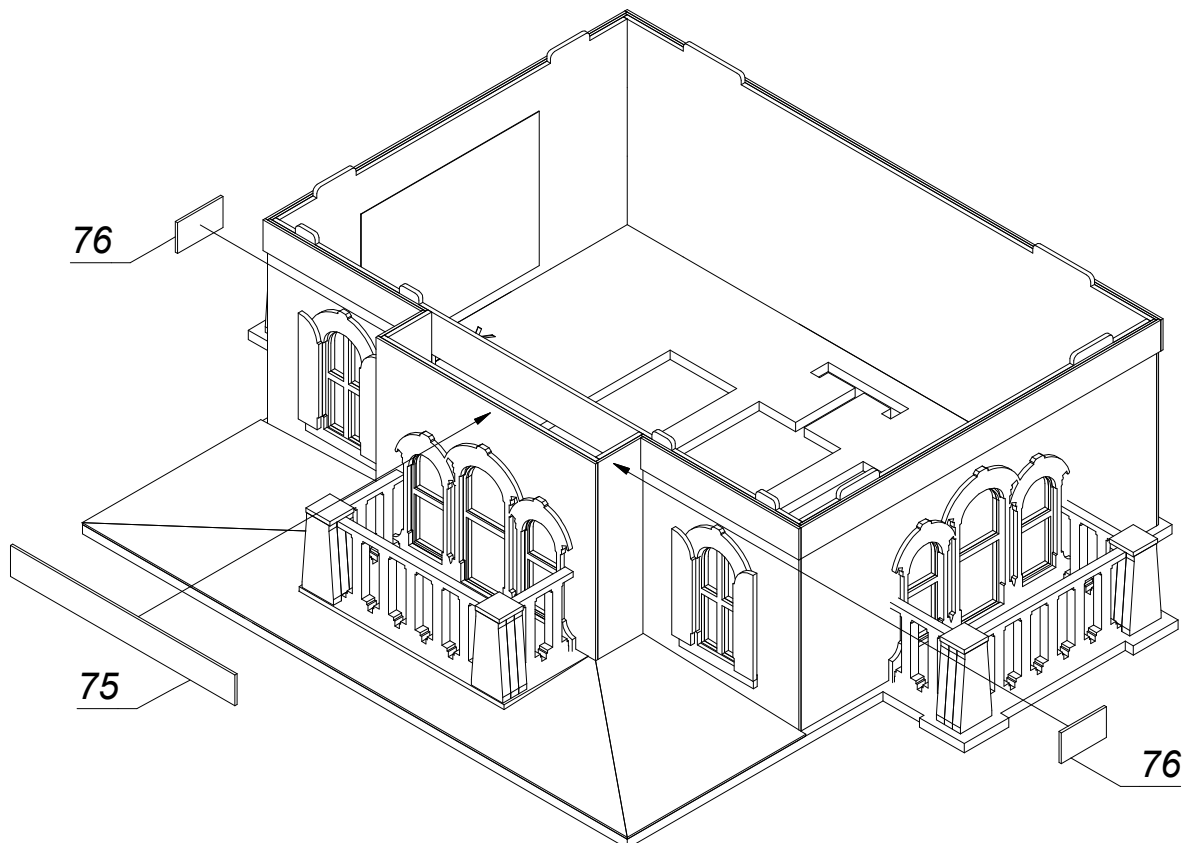

44.

15 (42x)

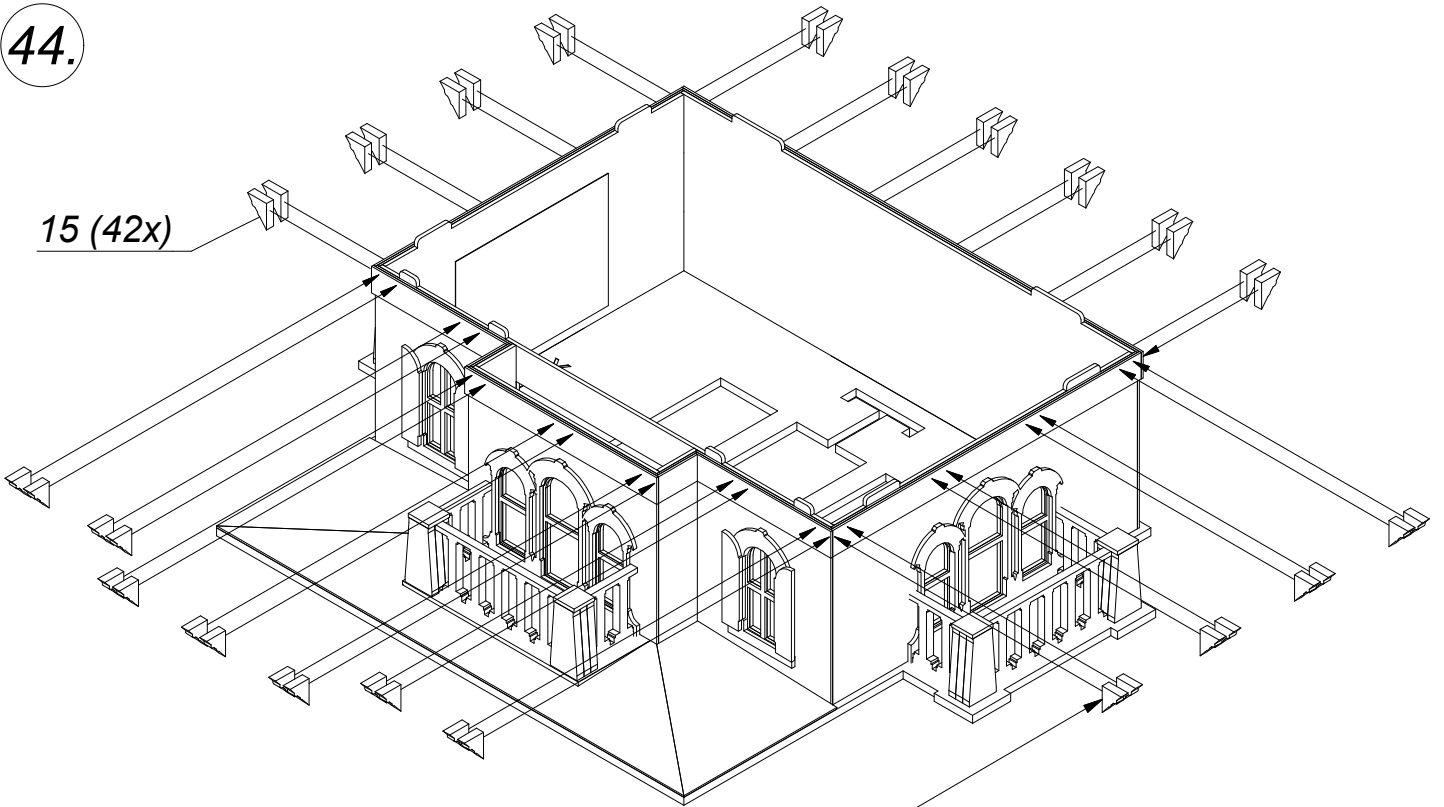

Achtung!
Langer Schenkel nach unten!

Attention!
Long side downwards.

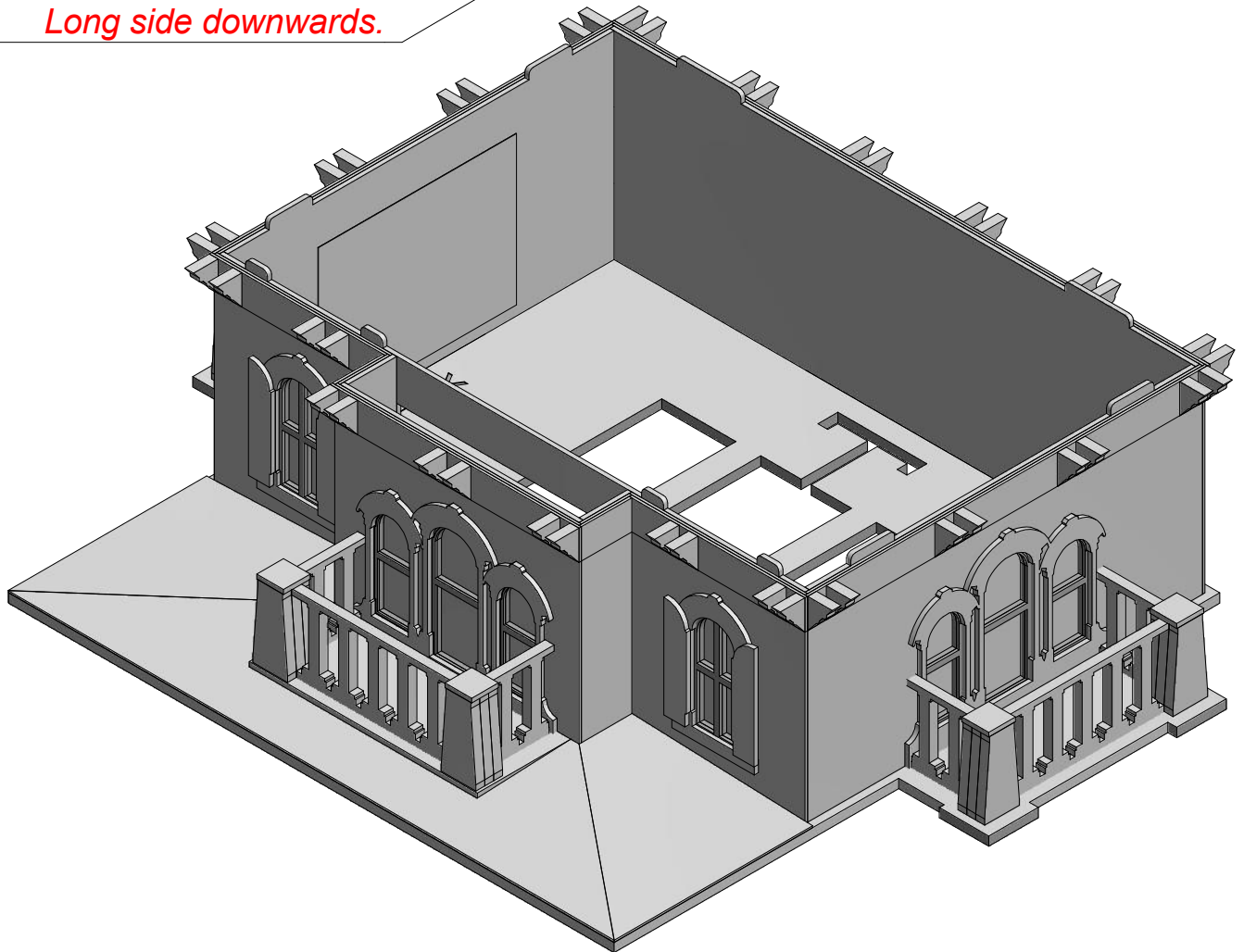

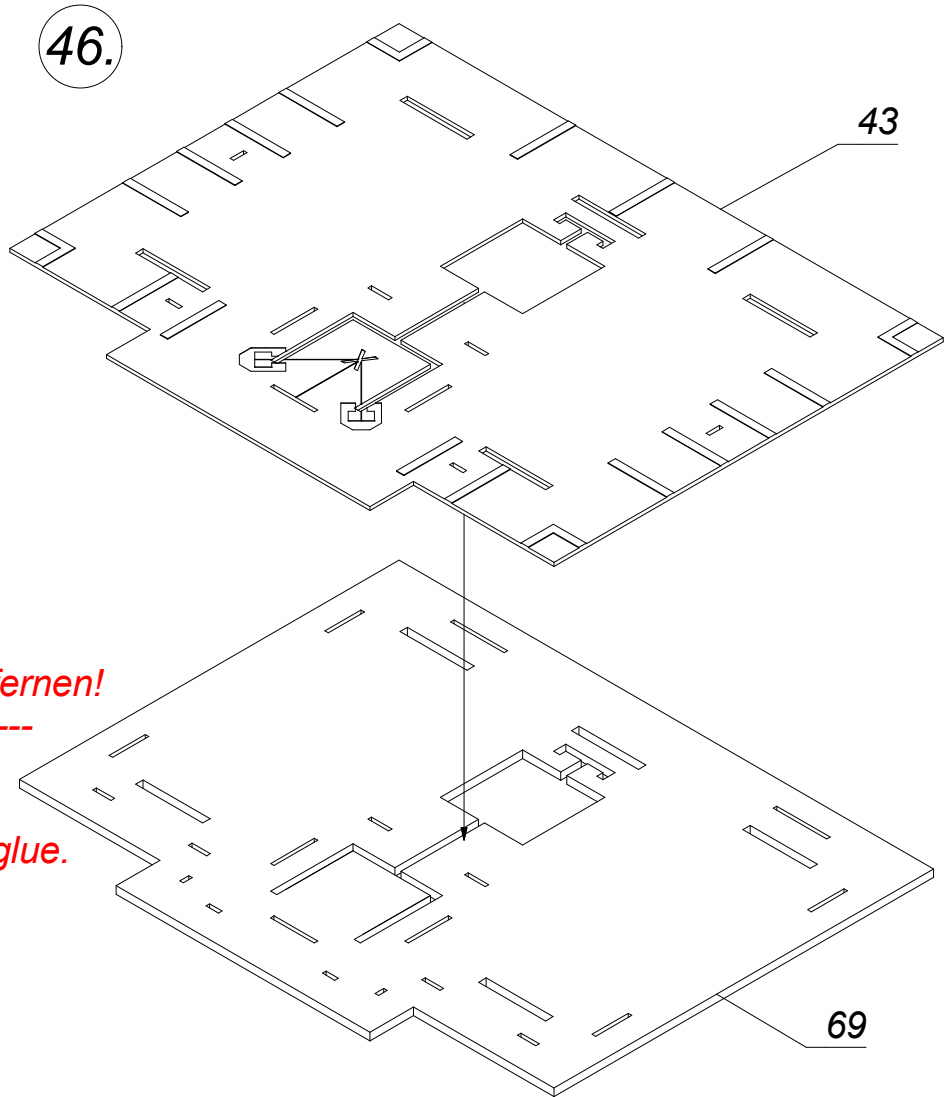
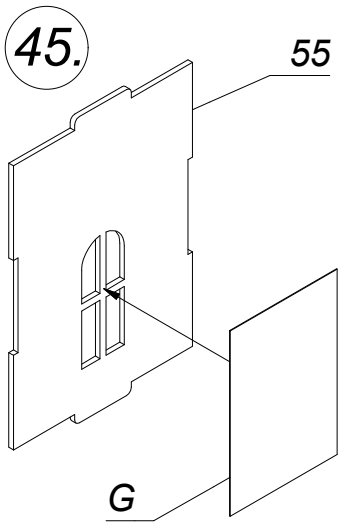

Achtung!
Sauber verkleben!
Kleberückstände entfernen!

Attention!
Glue accurately!
Remove residues of glue.

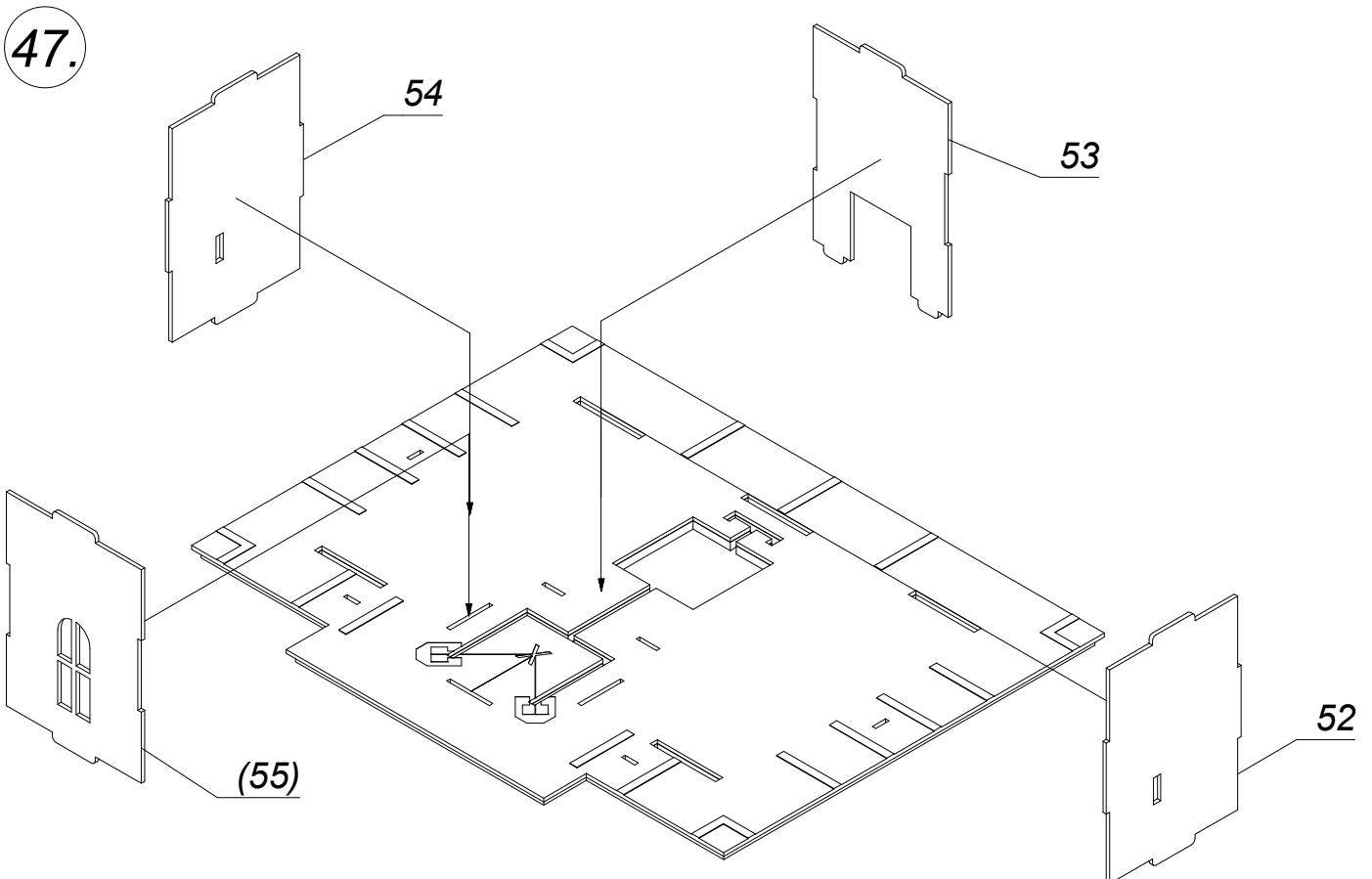

48.

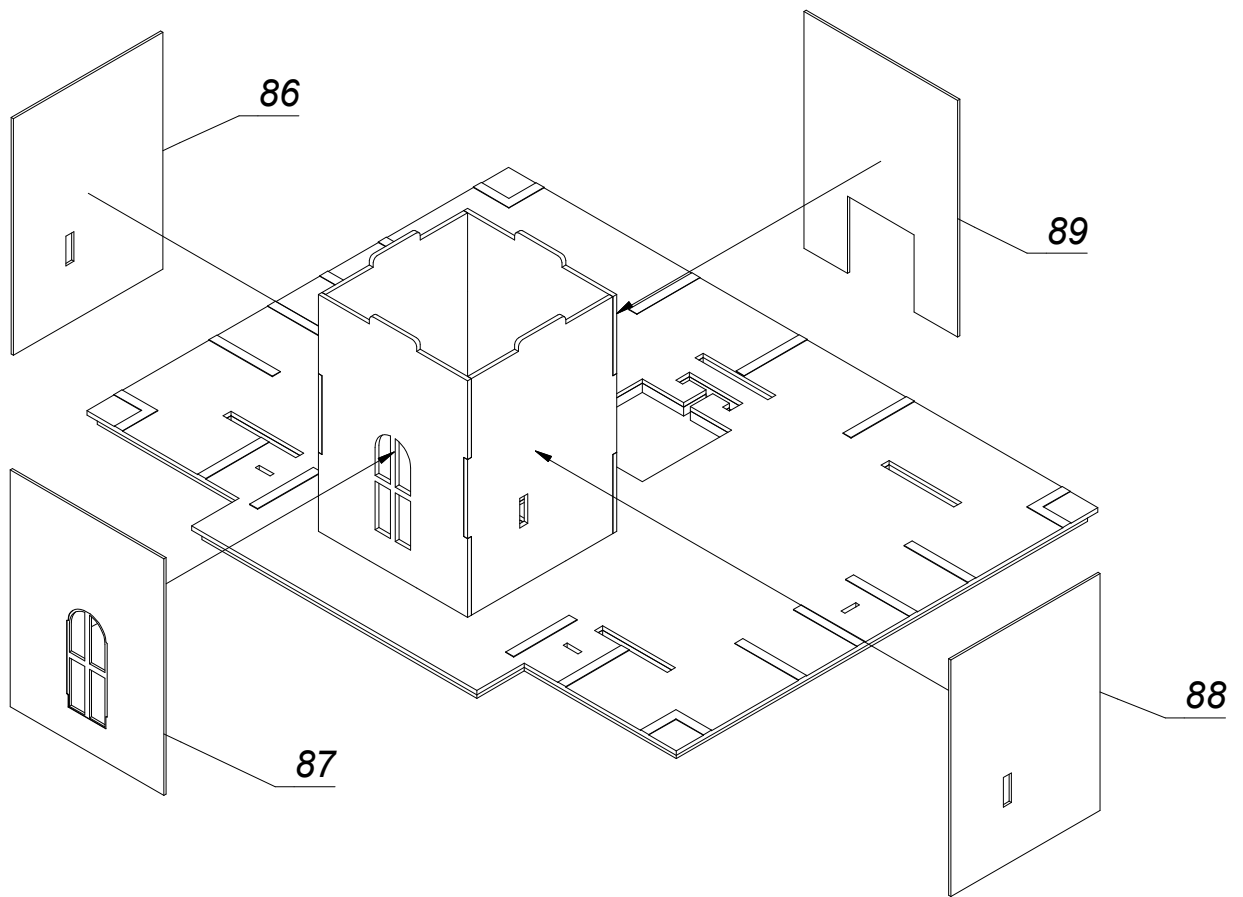

49.

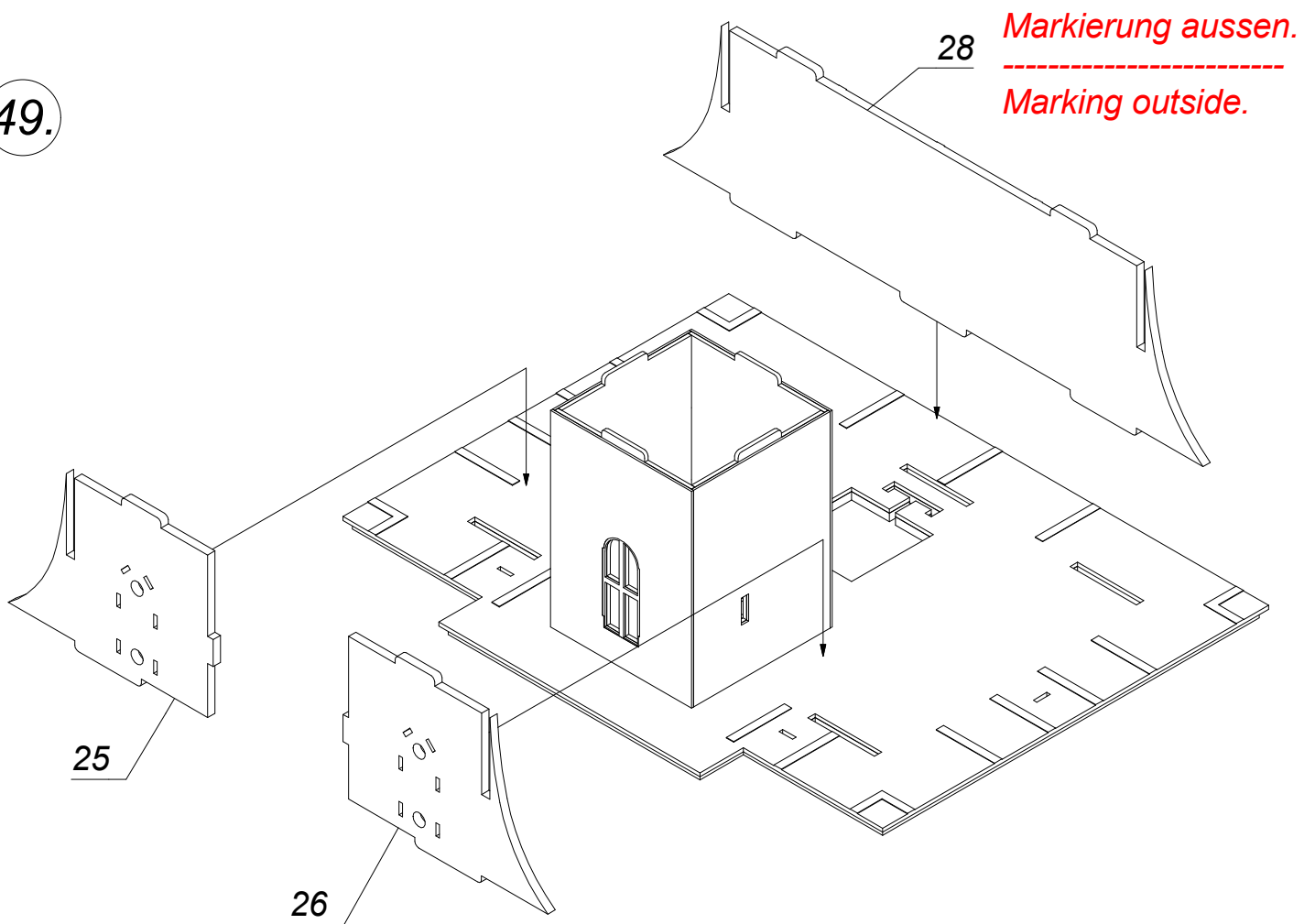

50.

27
Markierung aussen.

Marking outside.

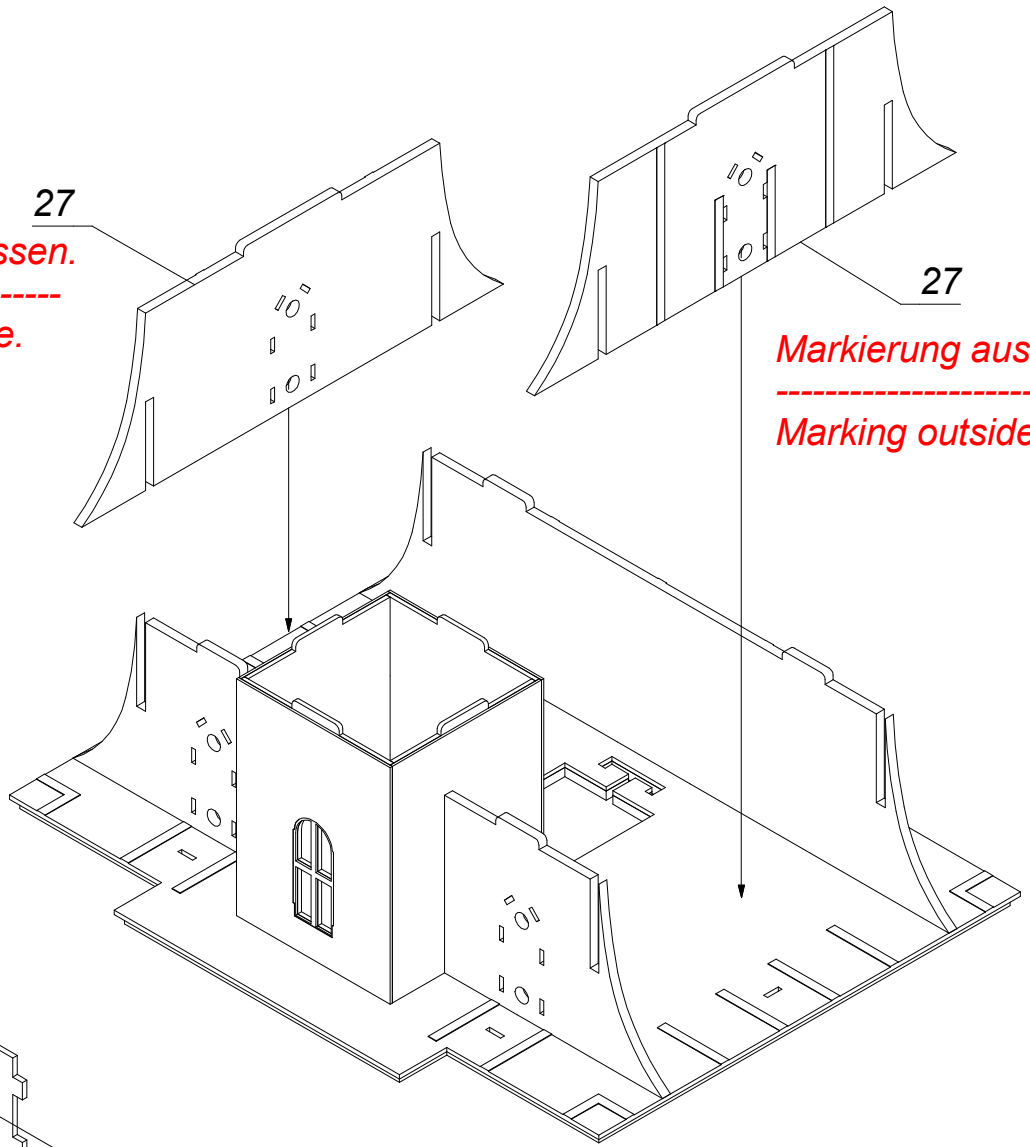

27
Markierung aussen.

Marking outside.

51.

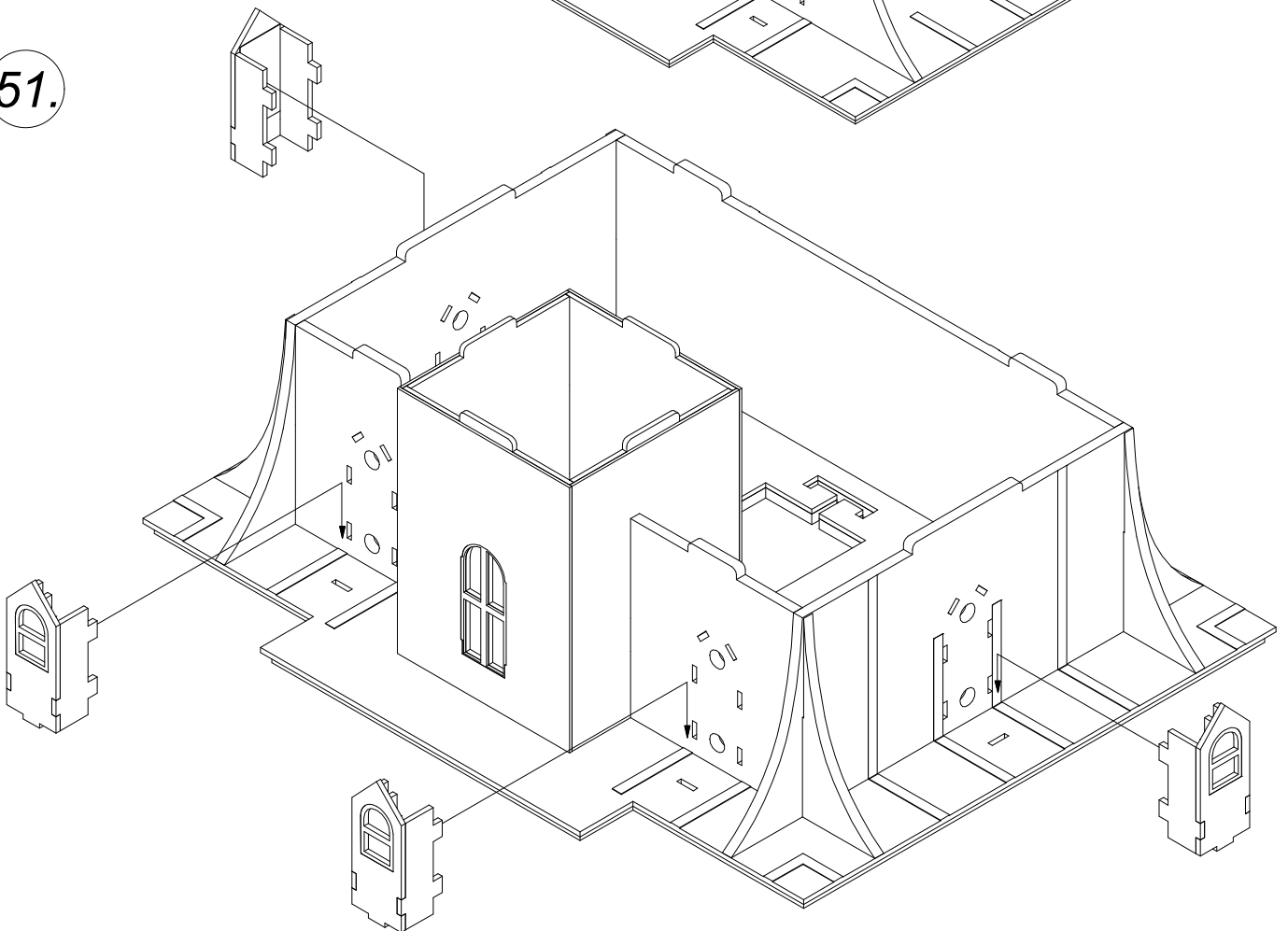

52.

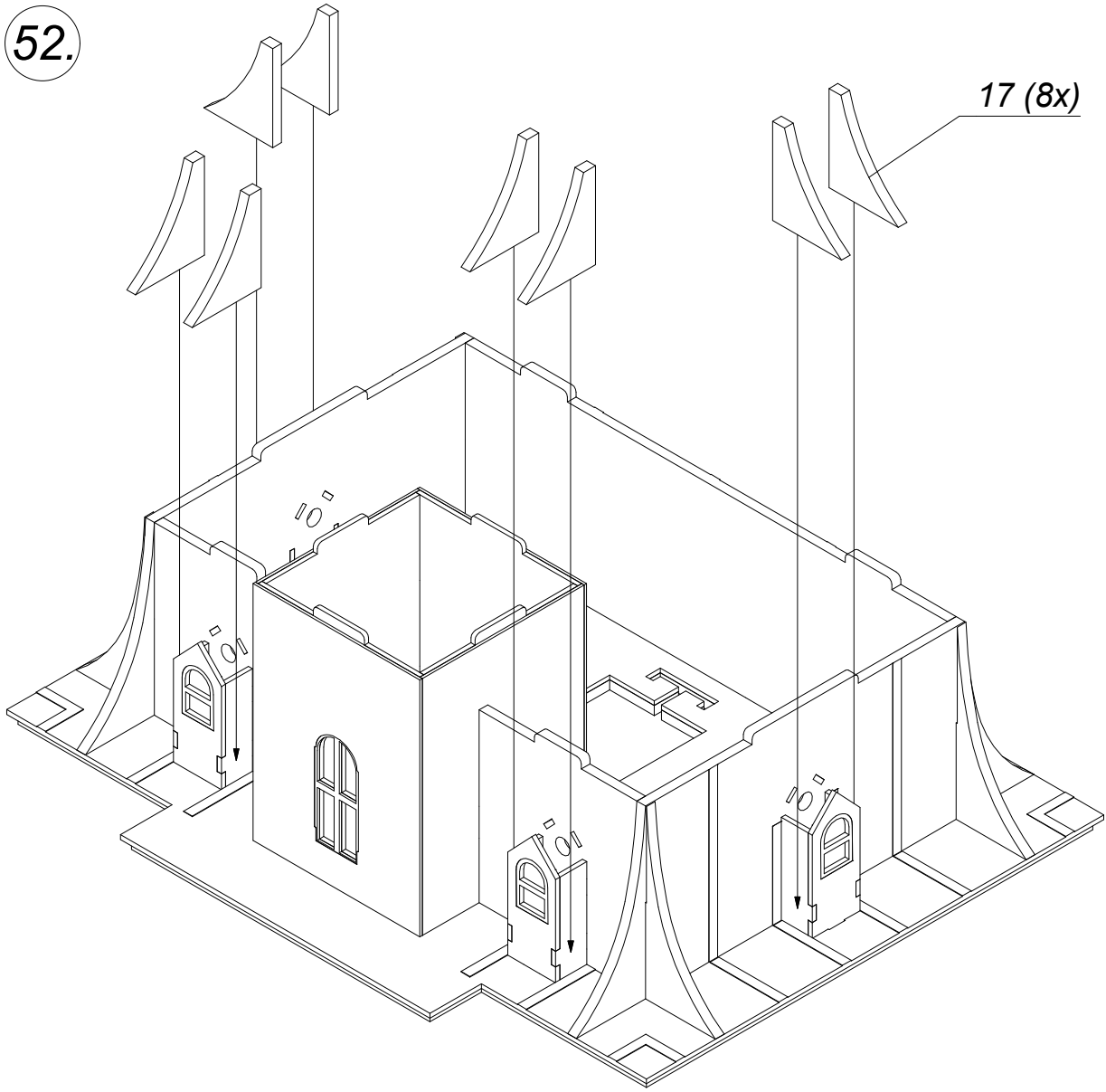

53.

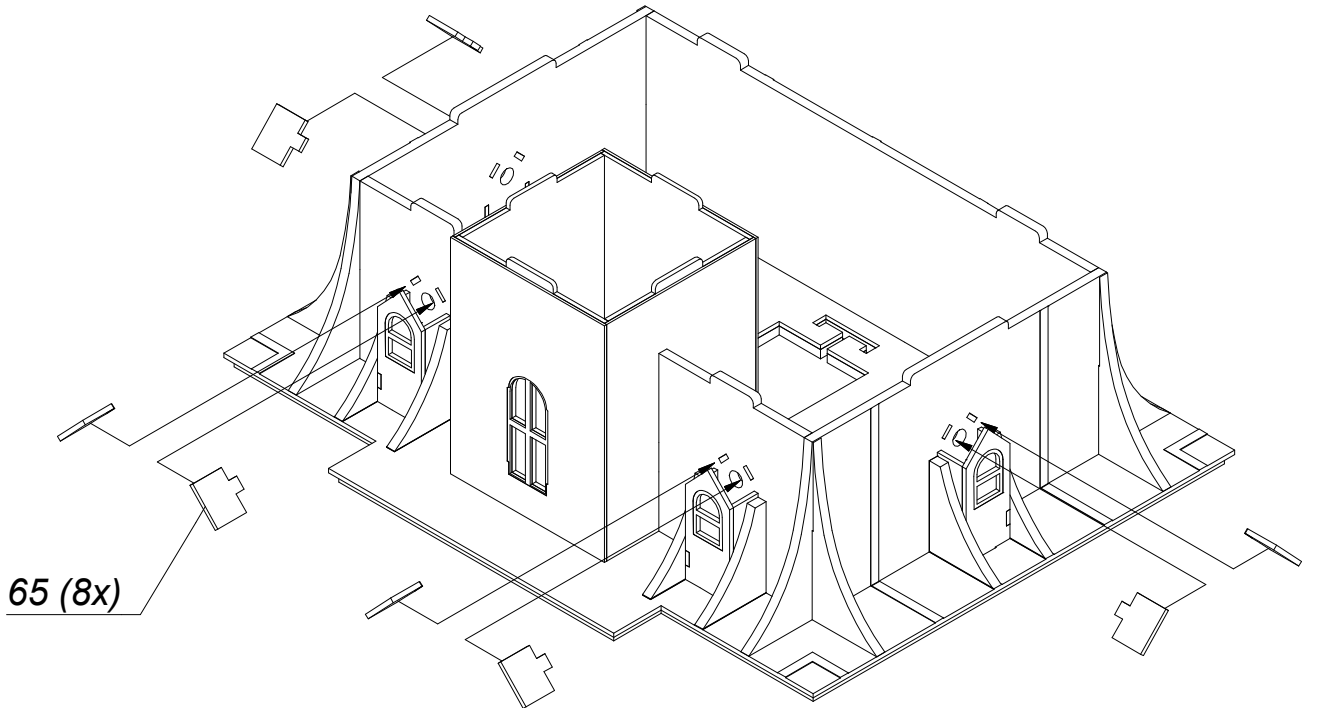

54.

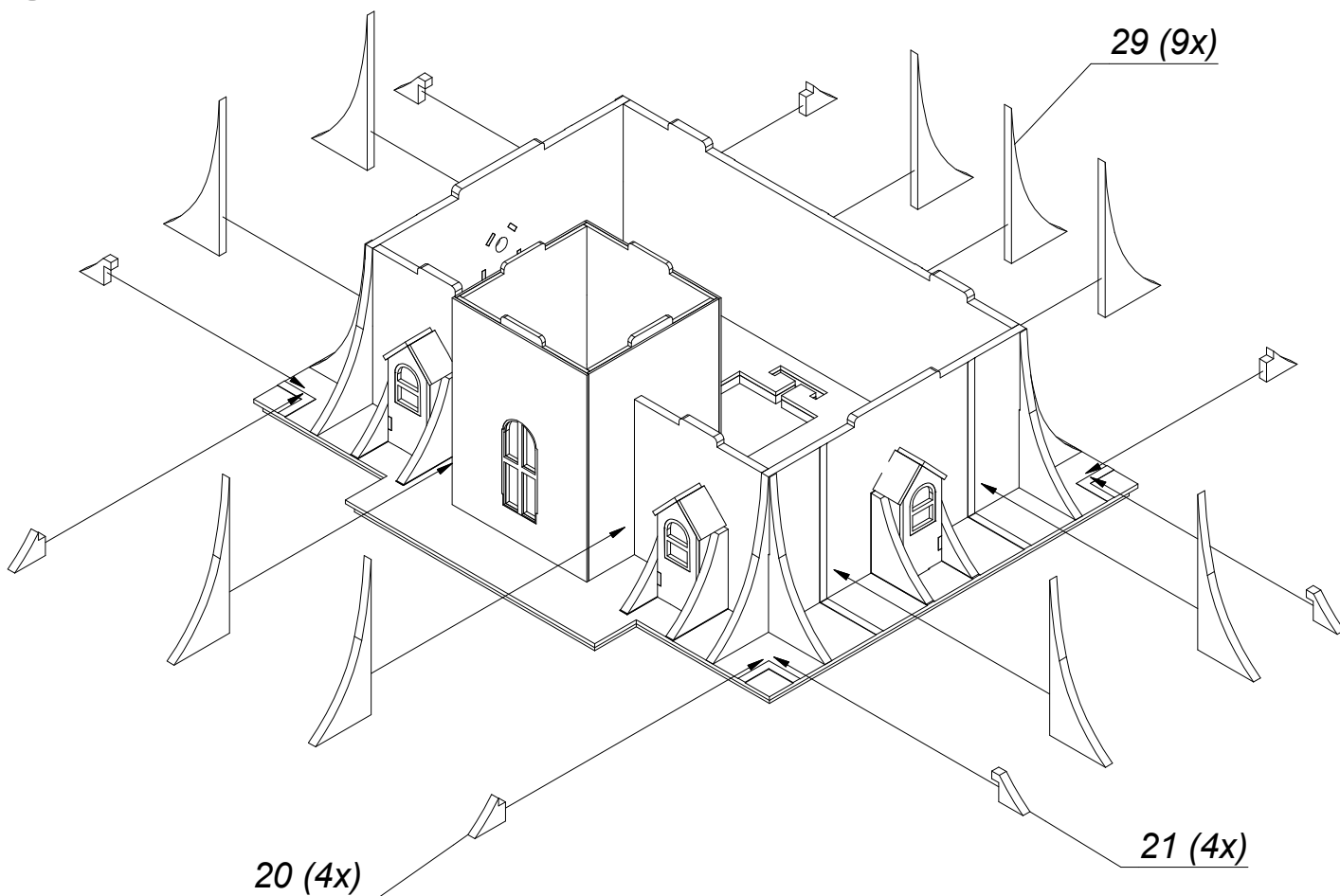

55.

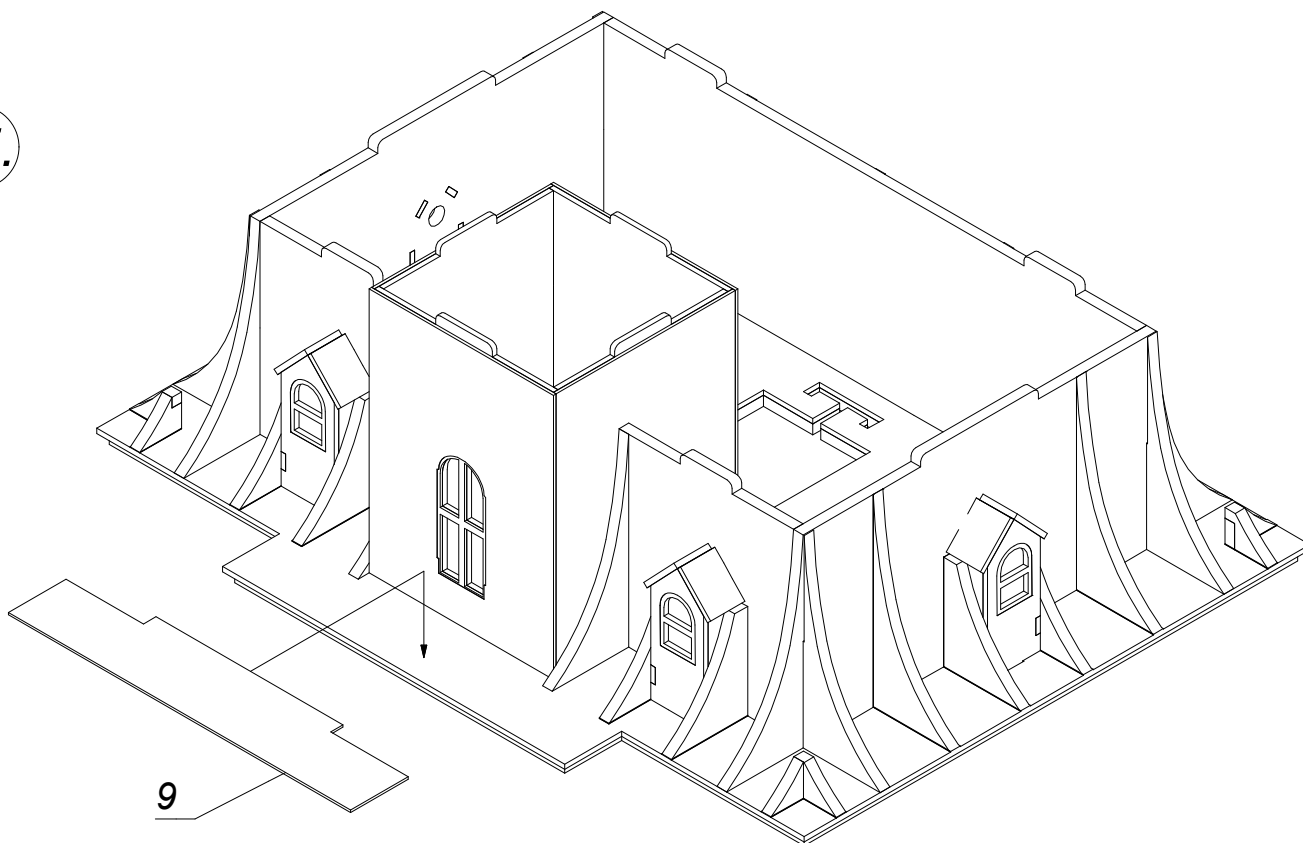

56.

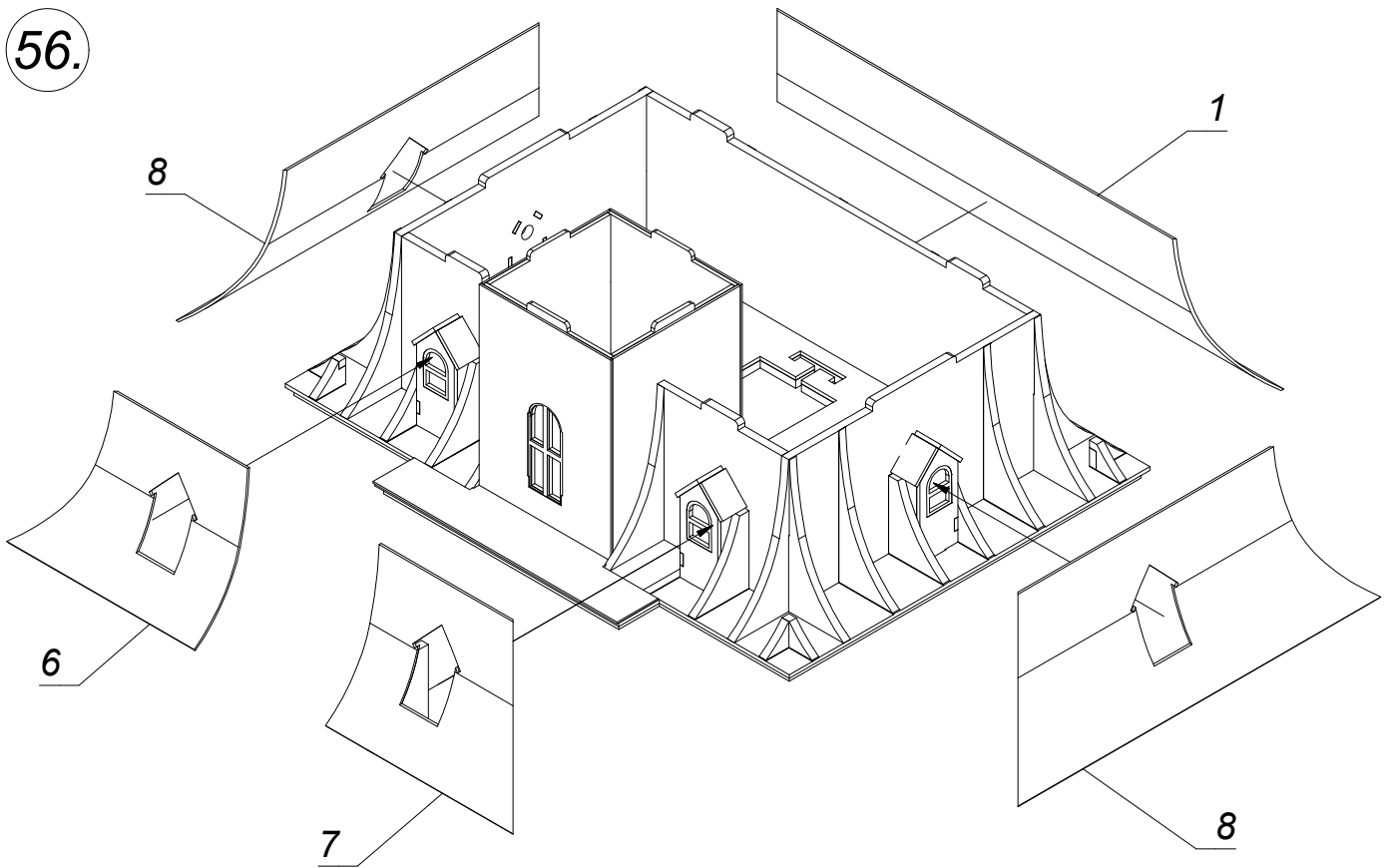

57.

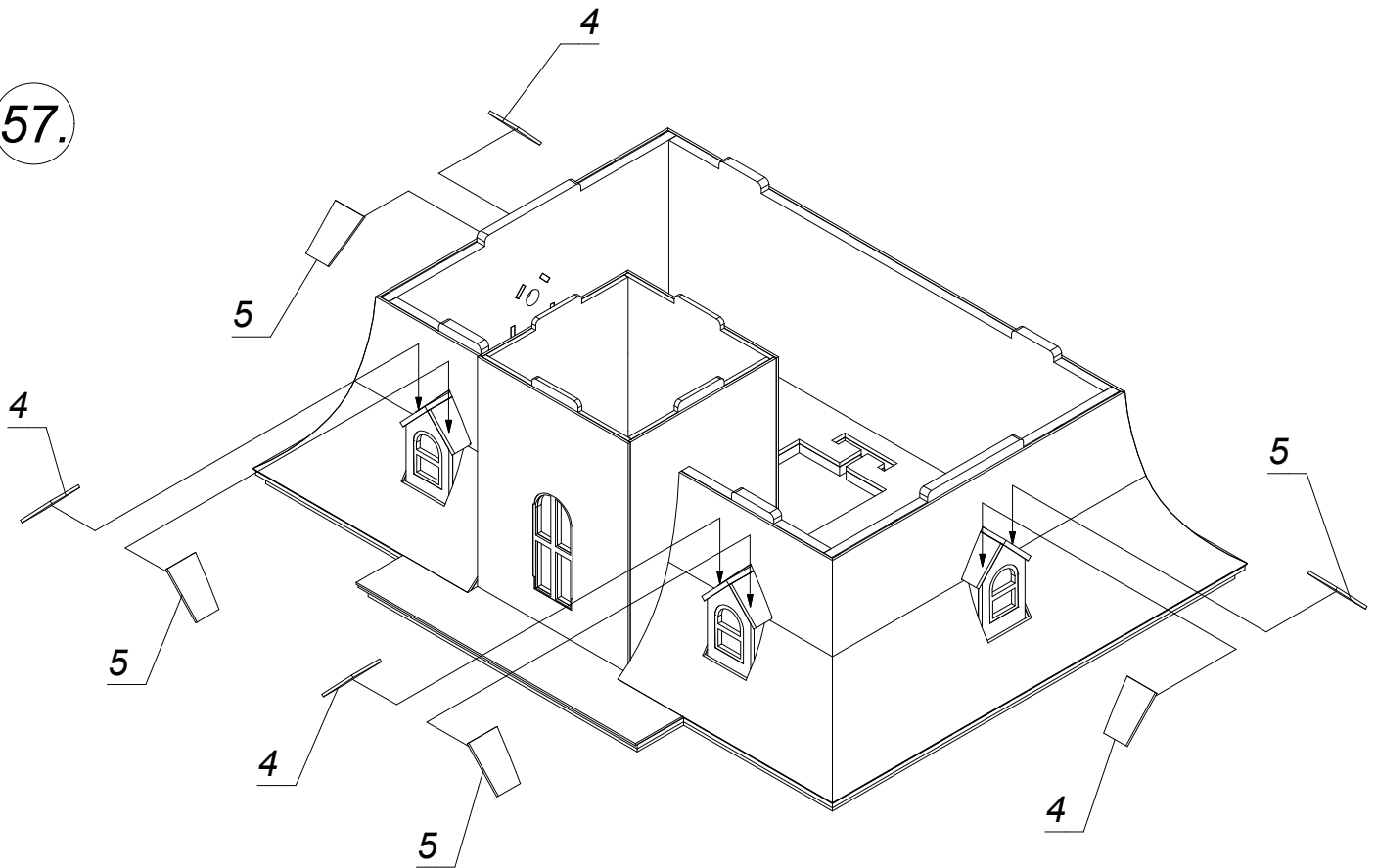

58.

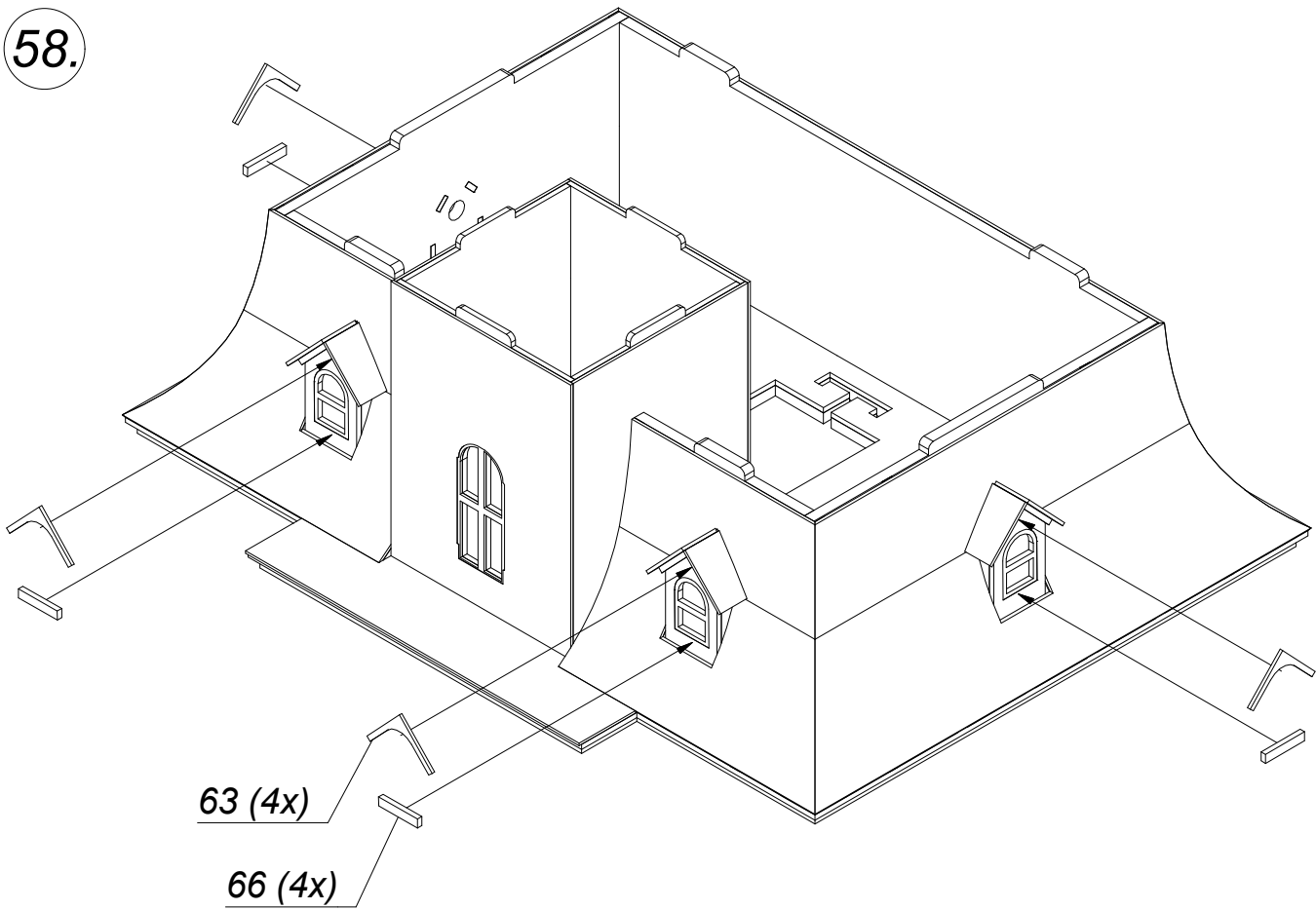

59.

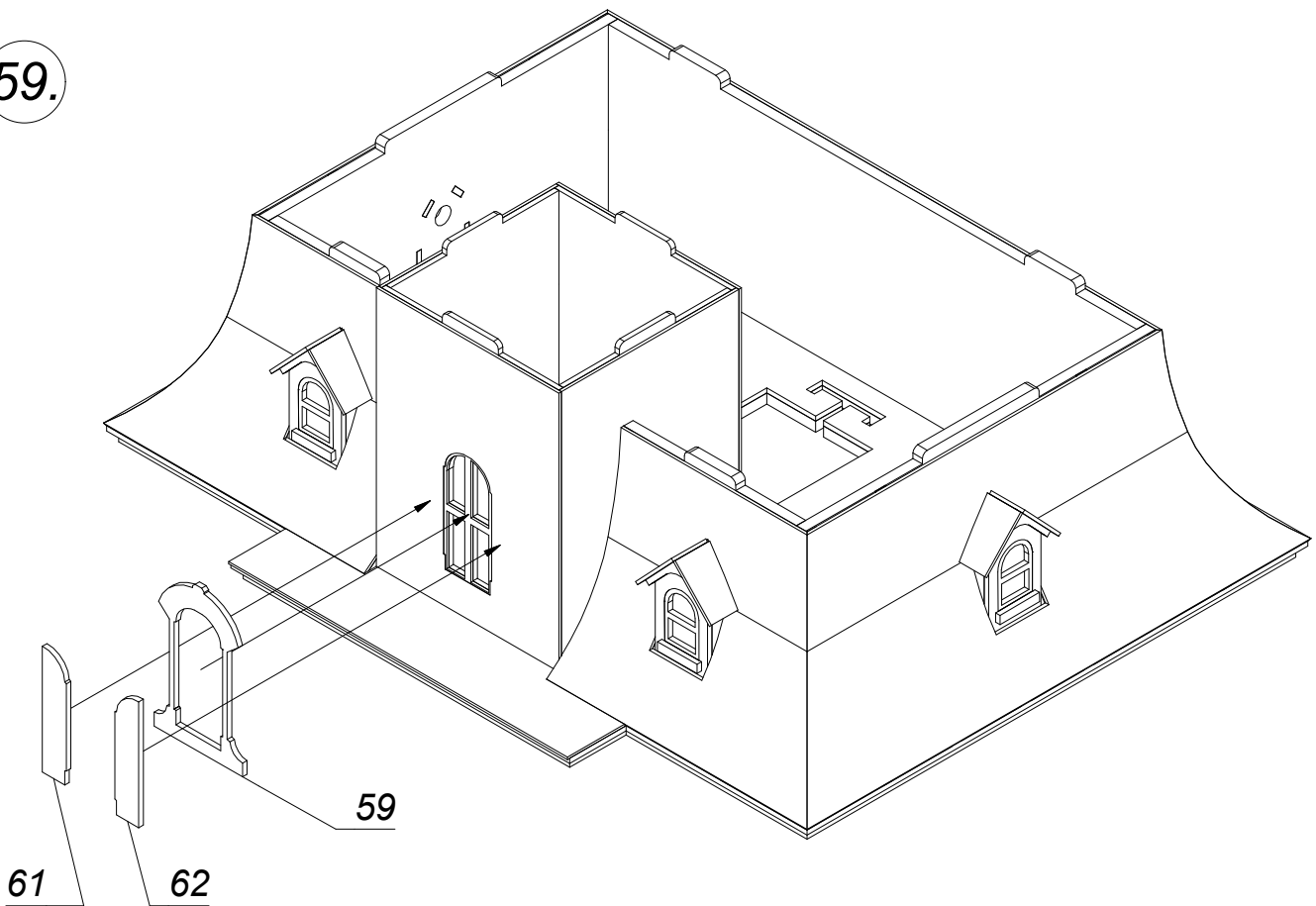

60.

79 (4x)

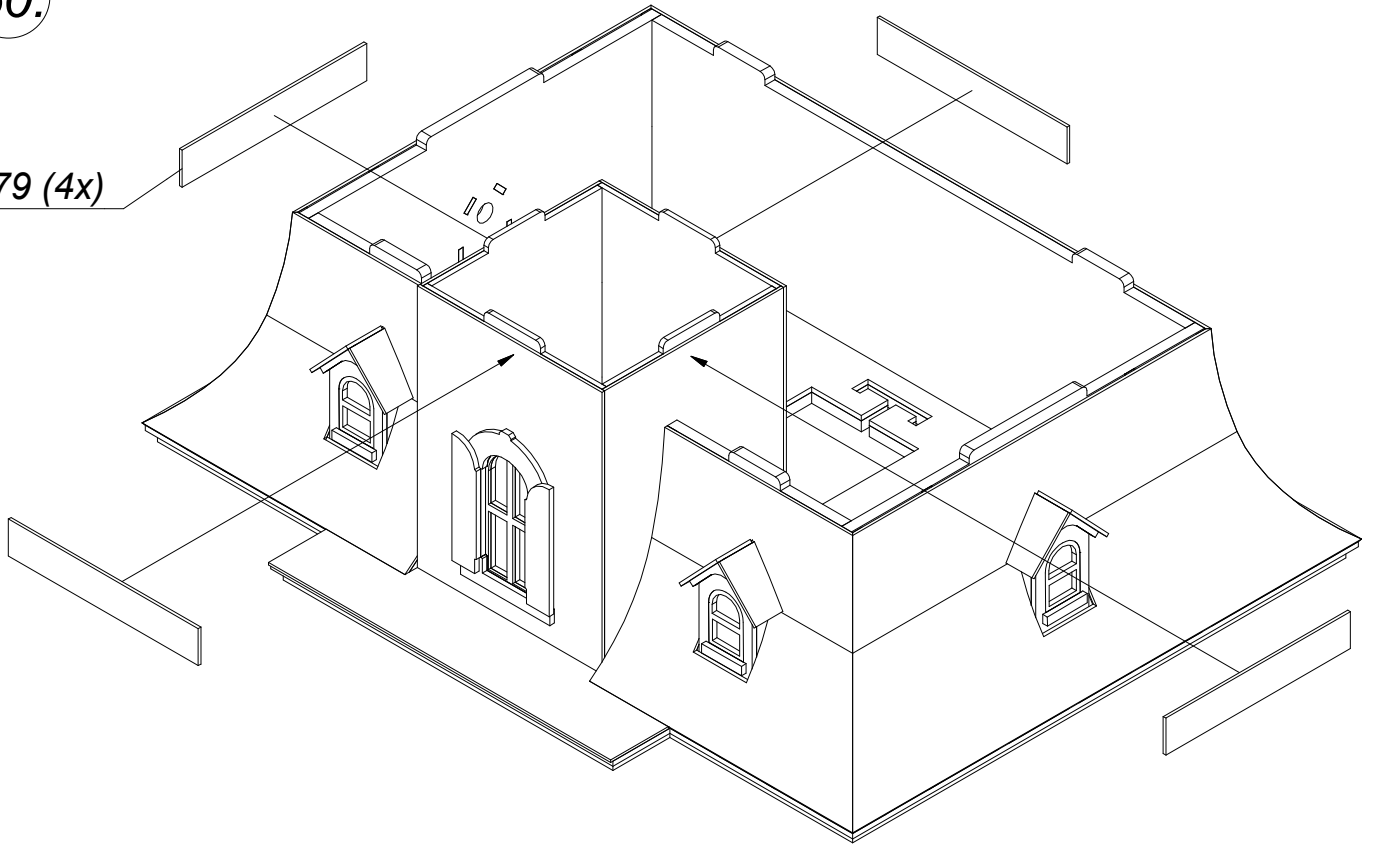

61.

15 (16x)

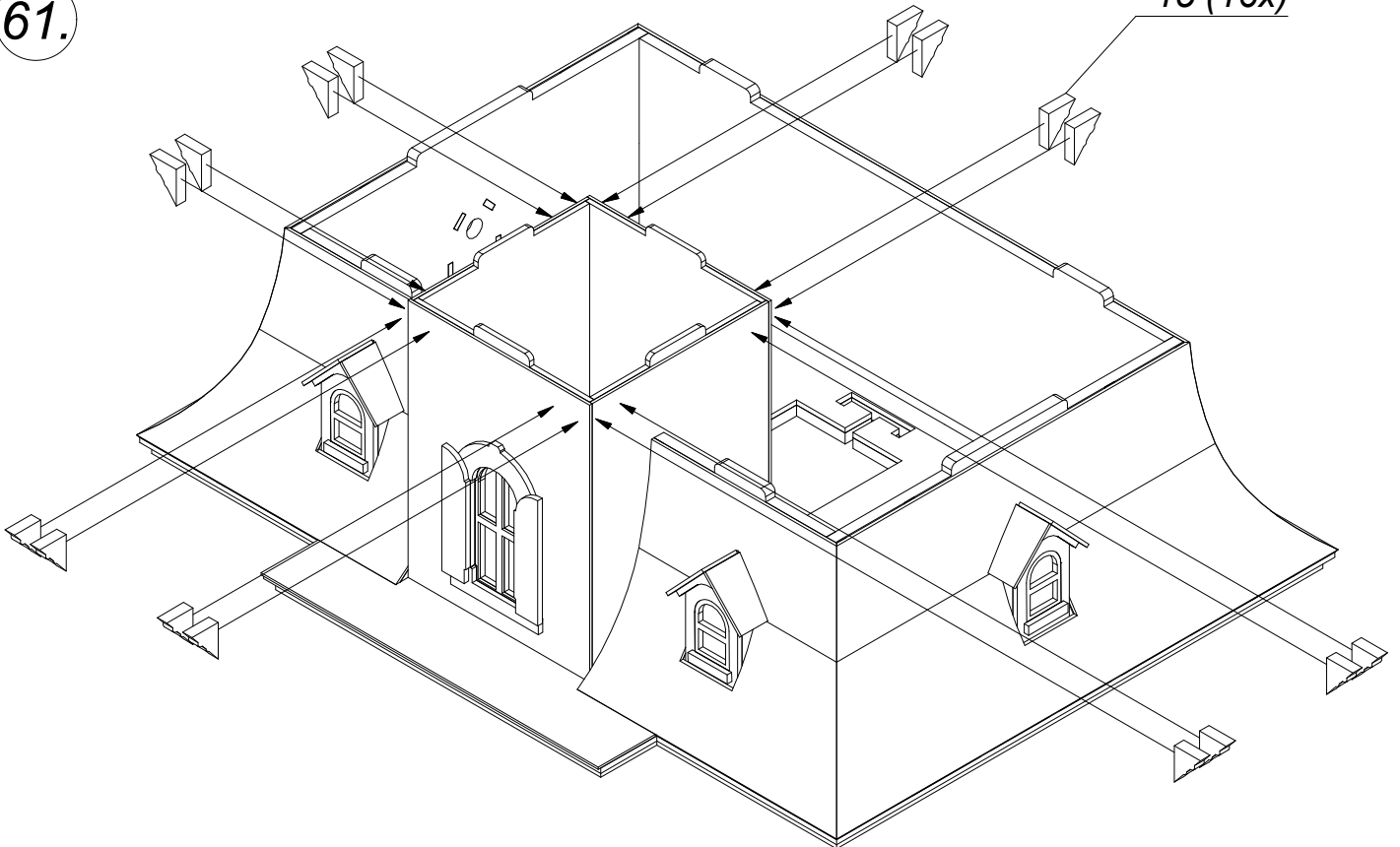

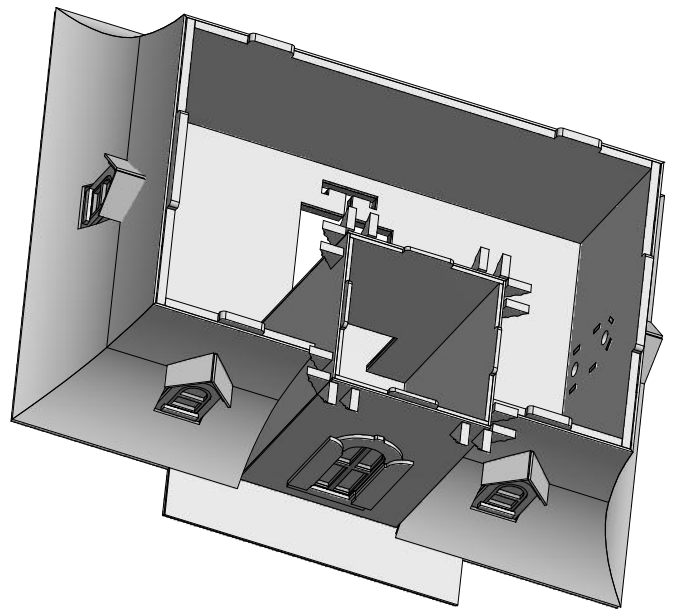
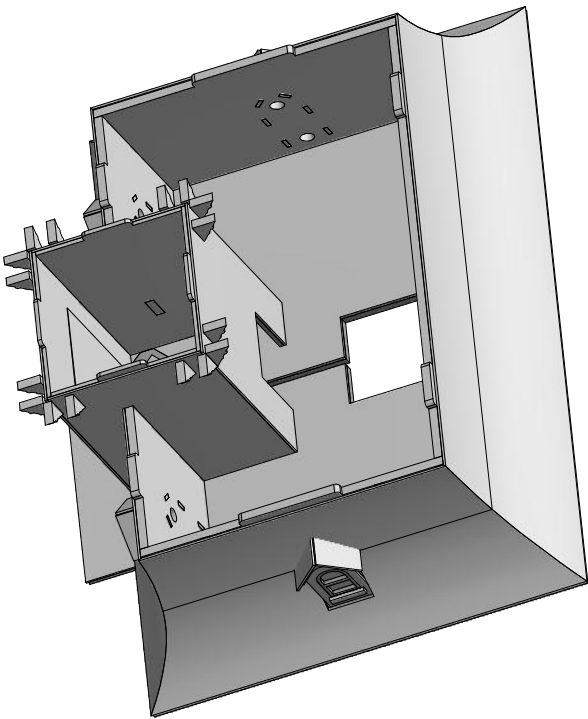
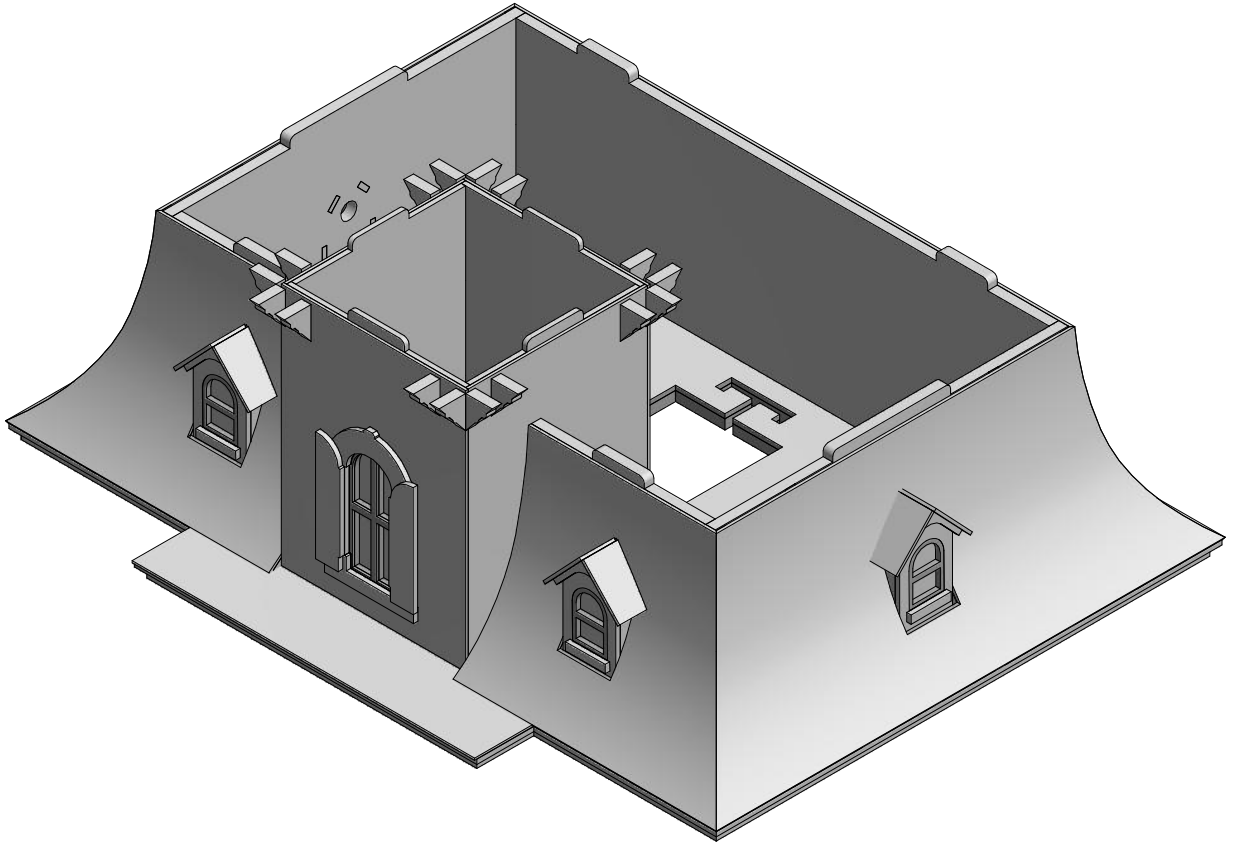

61.

Achtung!
Sauber verkleben!
Kleberückstände entfernen!

Attention!
Glue accurately!
Remove residues of glue.

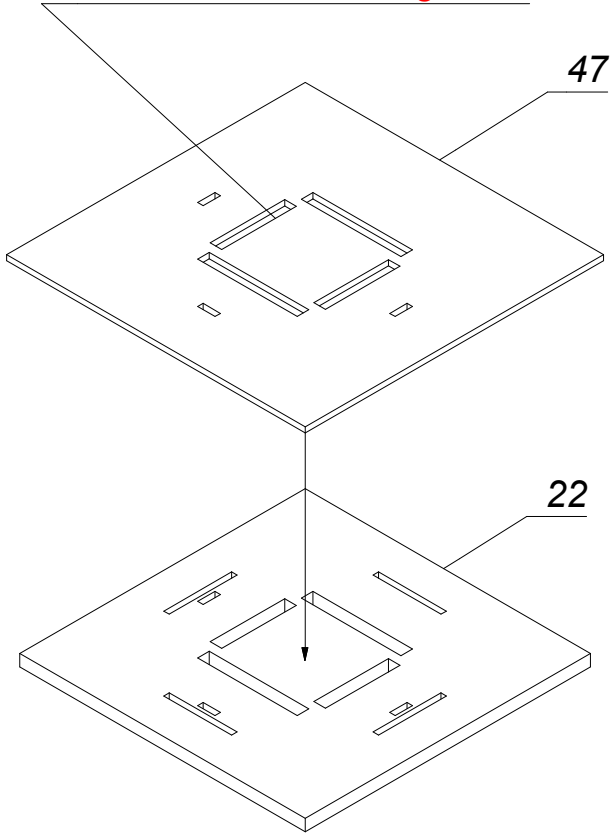

62.

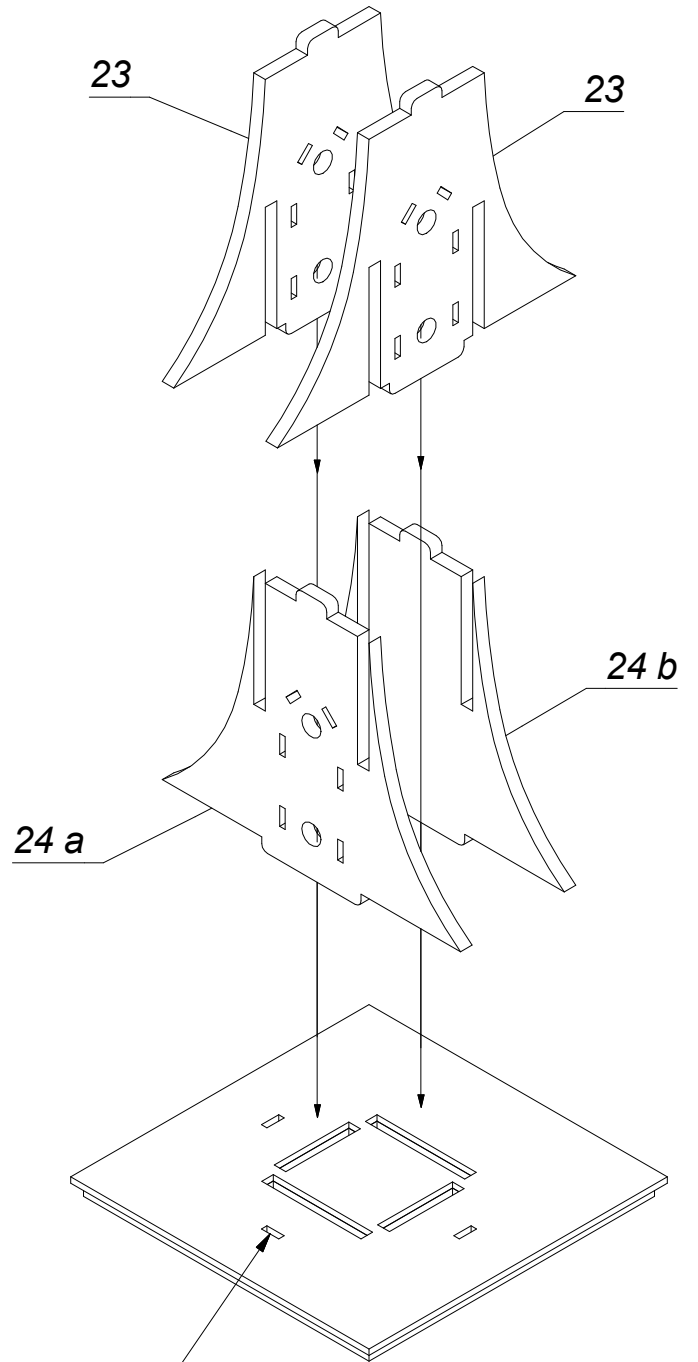

63.

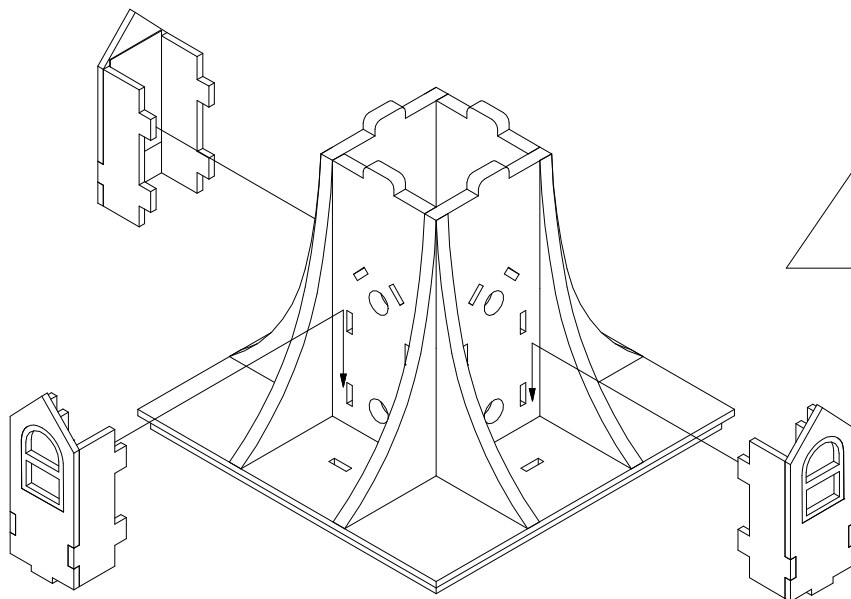

Auf richtige Ausrichtung achten!

Pay attention to correct position!

64.

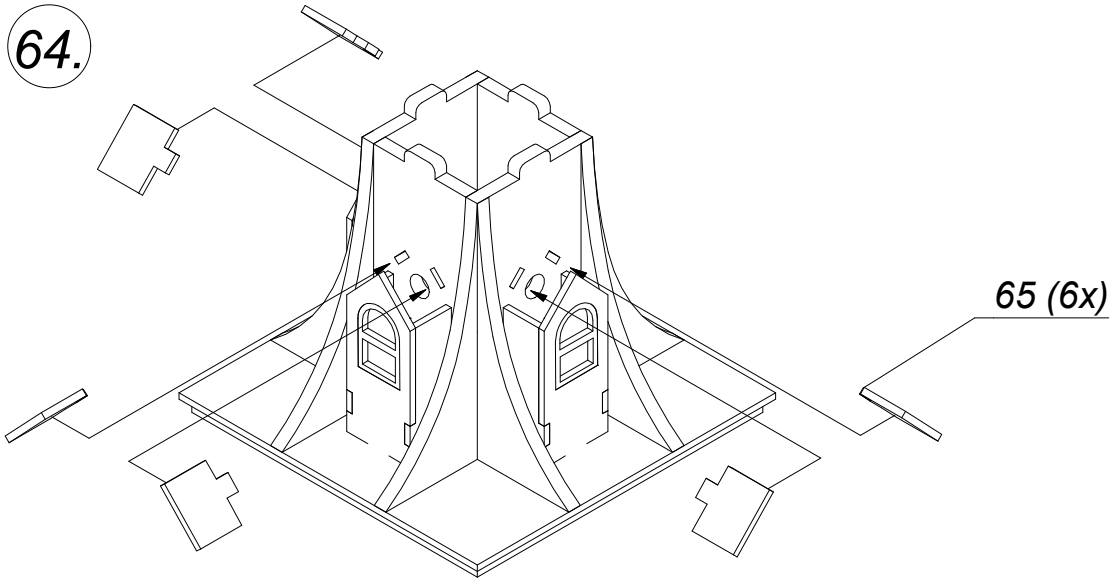

65.

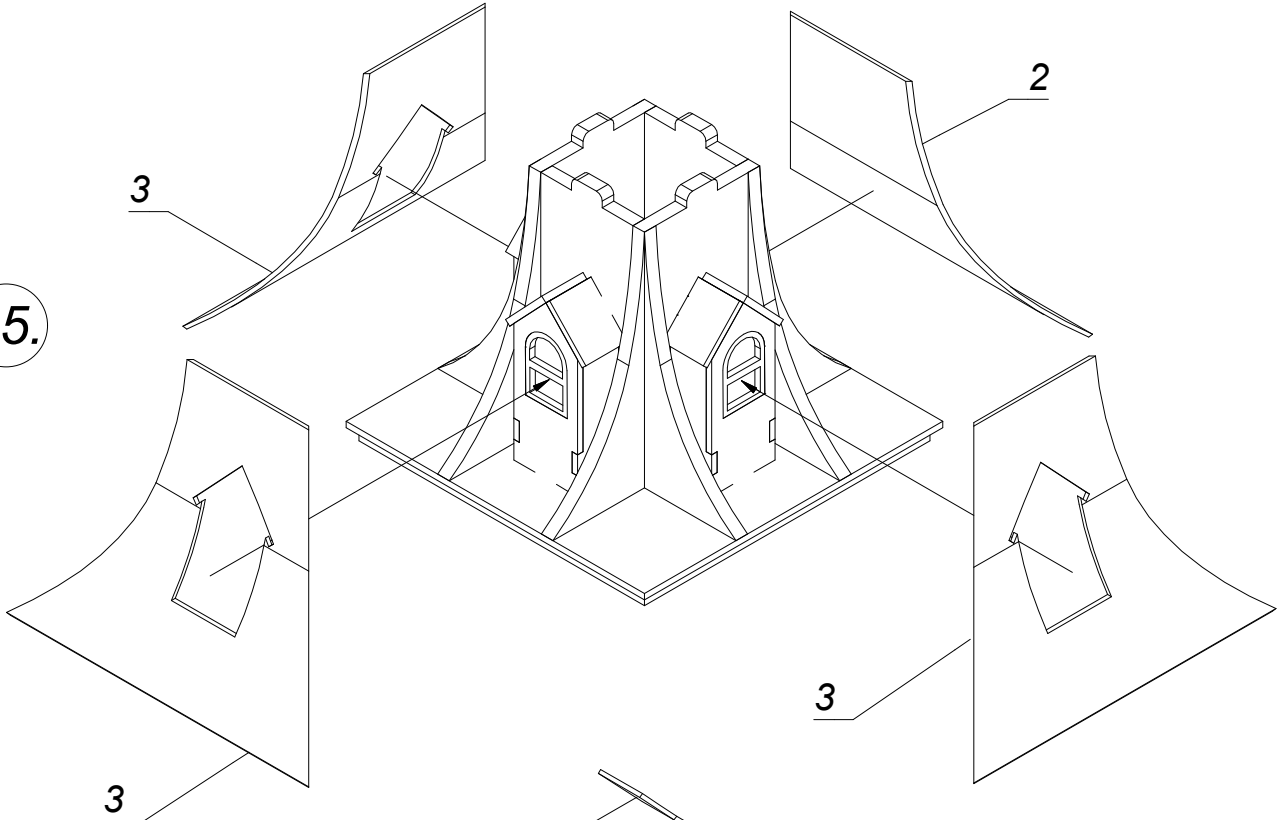

66.

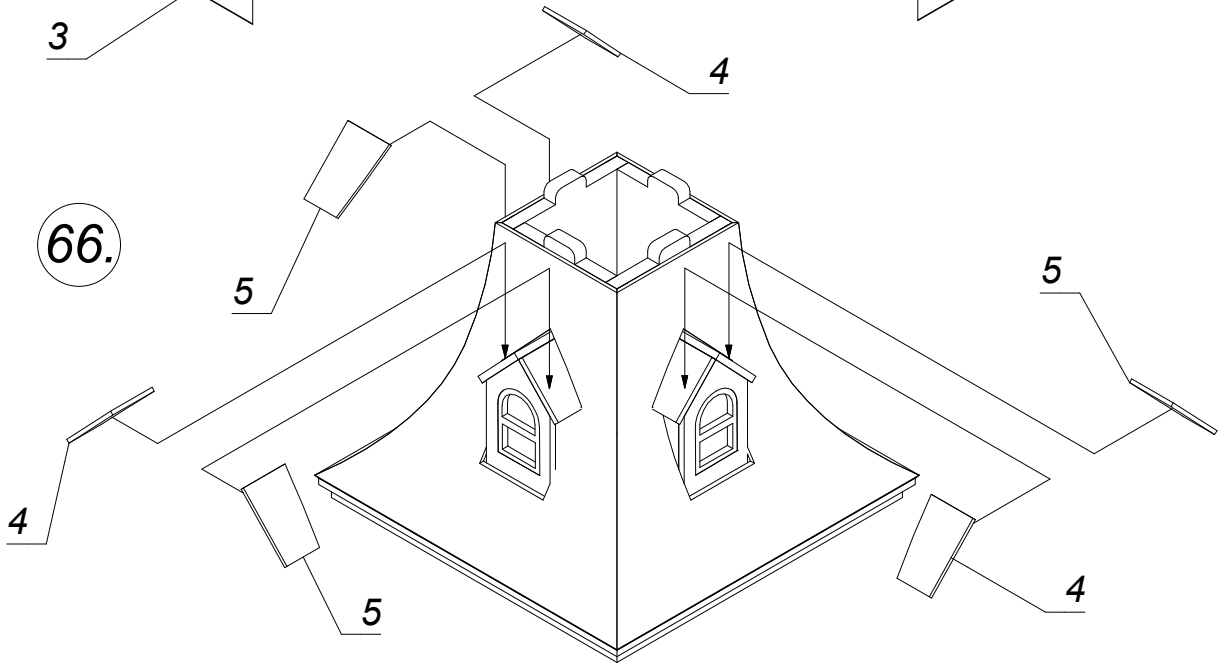

67.

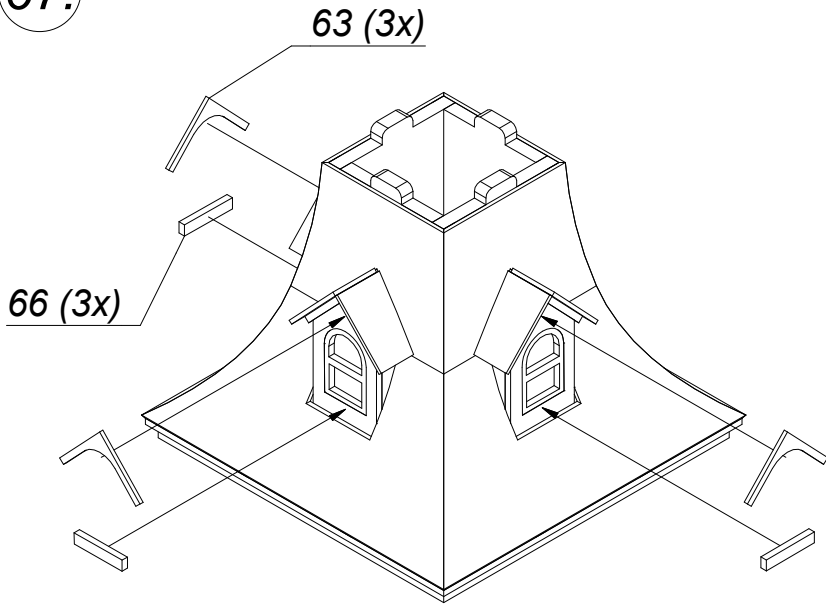

68.

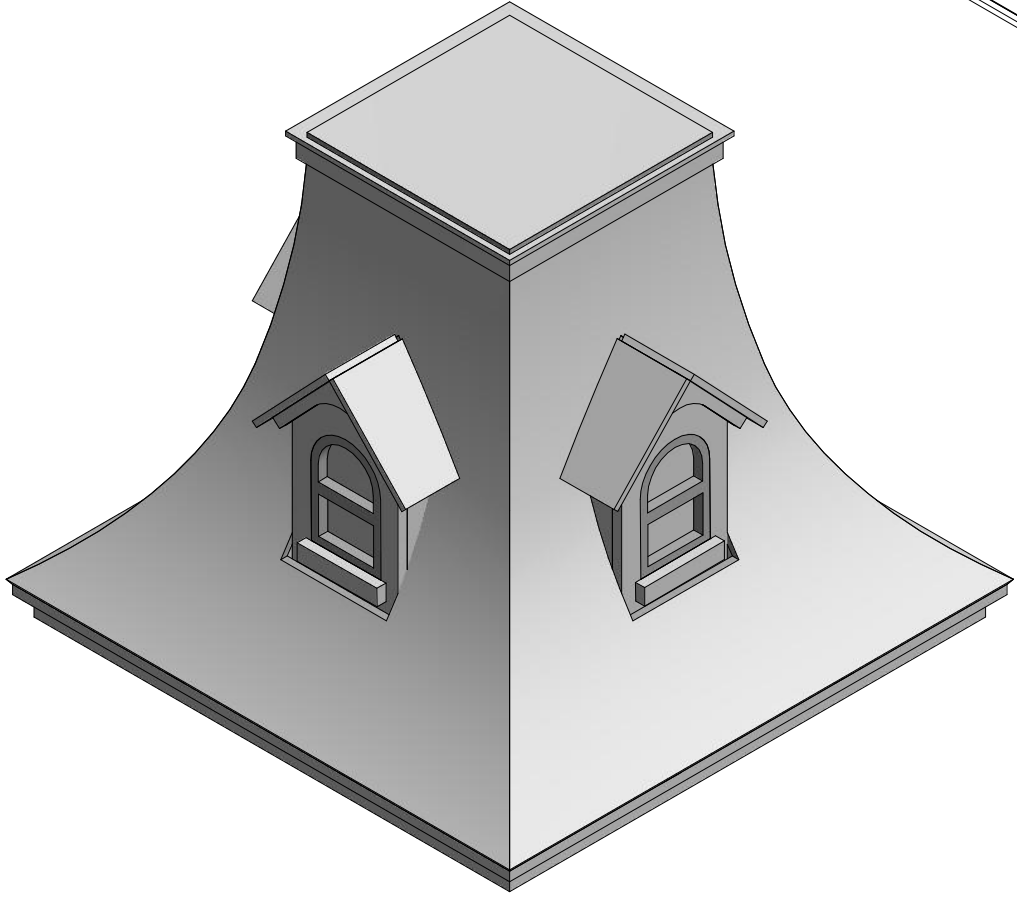
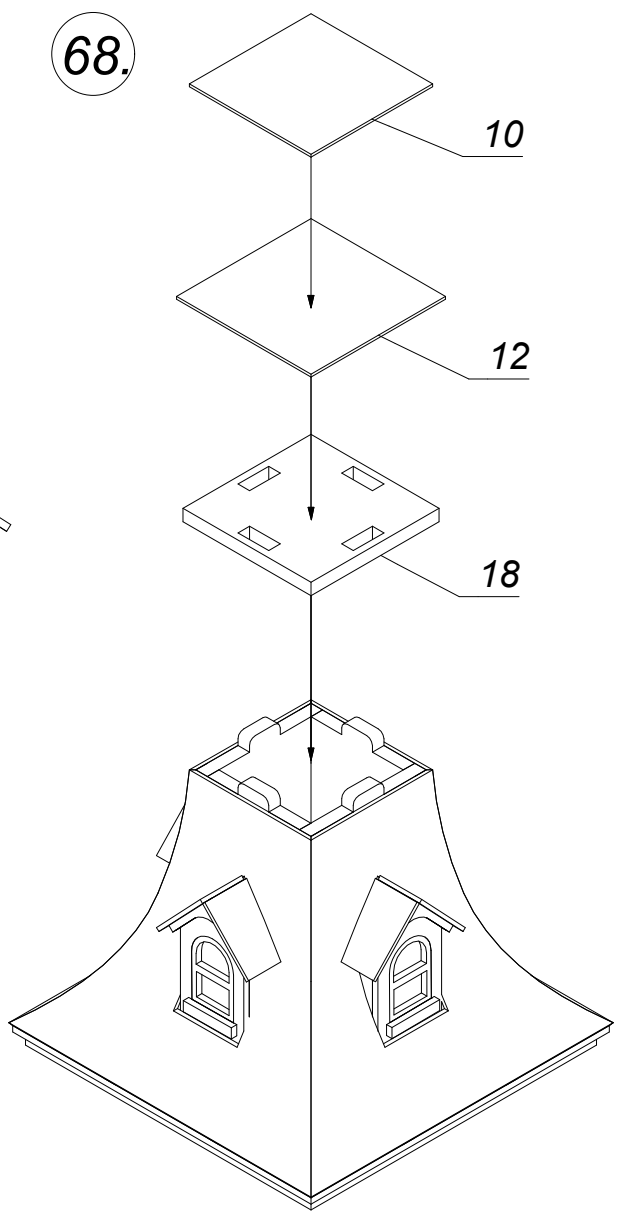

Übersicht der einzelnen Stockwerke.

Overview of the floors in detail.

Turm

tower

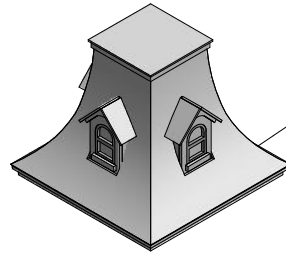

Dachgeschoss

top floor

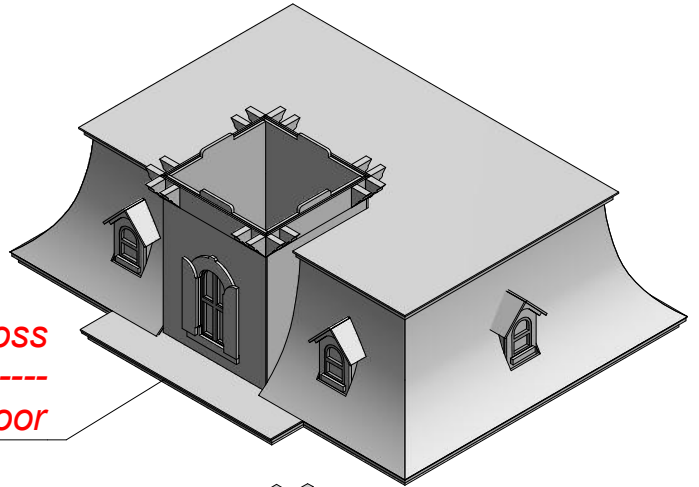

Nur zur Info.

For information only.

erstes Obergeschoss

upper floor

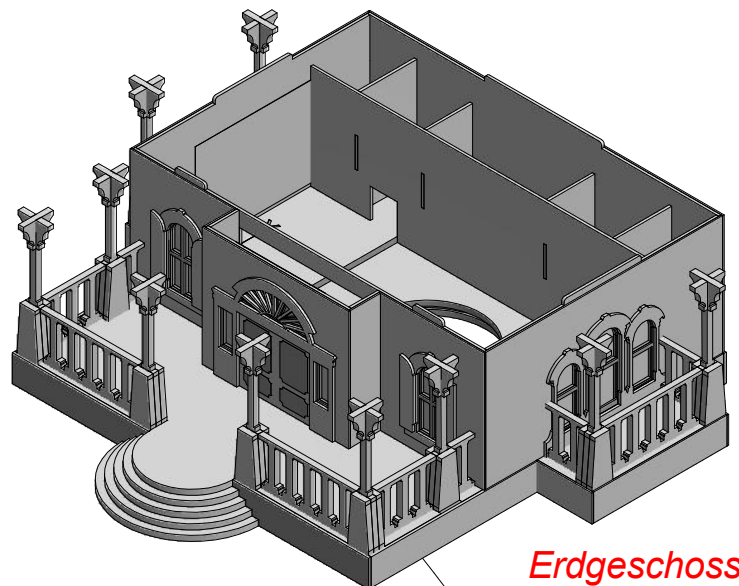
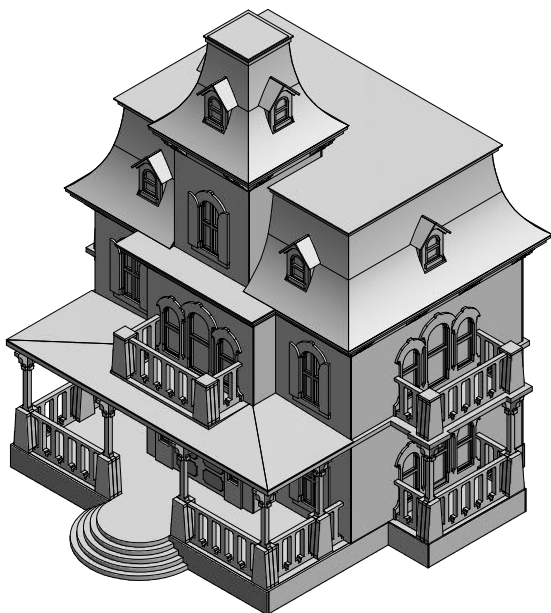
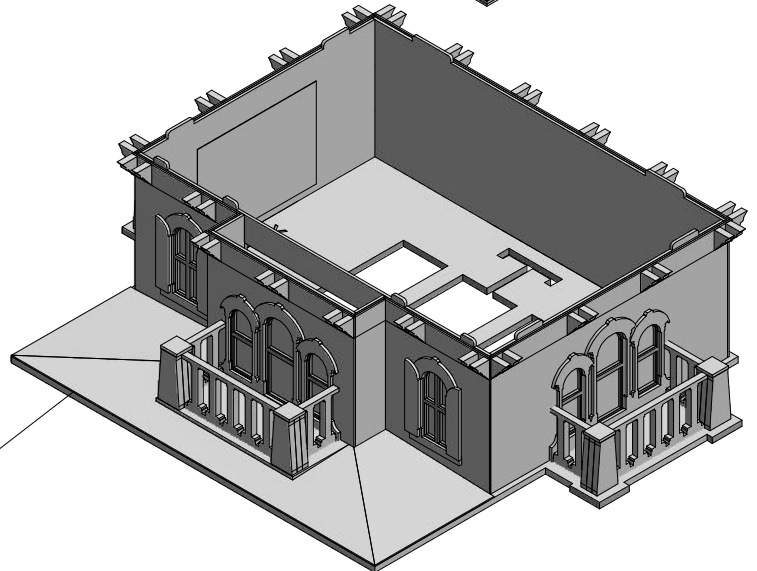

Erdgeschoss

ground floor

66990 Geisterhaus mit micro-sound Geisterheulen und Lichteffekten H0

Haunted House with micro-sound Ghost Howling and Light Effects H0

Manoir hanté avec micro-sound hurlements de fantômes et effets lumineux H0

Casa del terror con micro-sonido aullidos de fantasmas y efectos luminosos H0

Spookhuis met micro-sound spook gehuil en lichteffecten H0

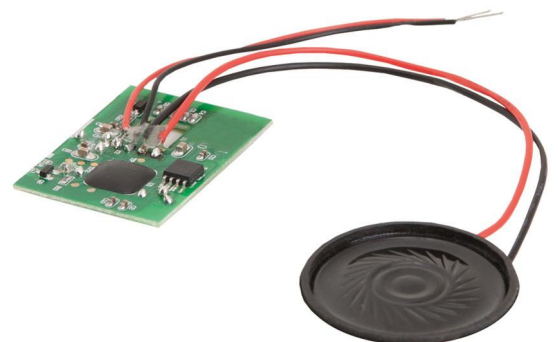

ACHTUNG: Die nachfolgende Warnung bitte unbedingt beachten.
LEDs senden ein sehr helles Licht aus, das gefährlich für das menschliche Auge sein kann.
NICHT in den Lichtstrahl hineinschauen !!!!!

ATTENTION: Please note the following warning carefully:
These LEDs emit highly concentrated light which can be hazardous to the human eye.
Do not look directly into the LED light !!!!!

Vor dem Einbau Elektronik testen.

Test the electronic unit before mounting.

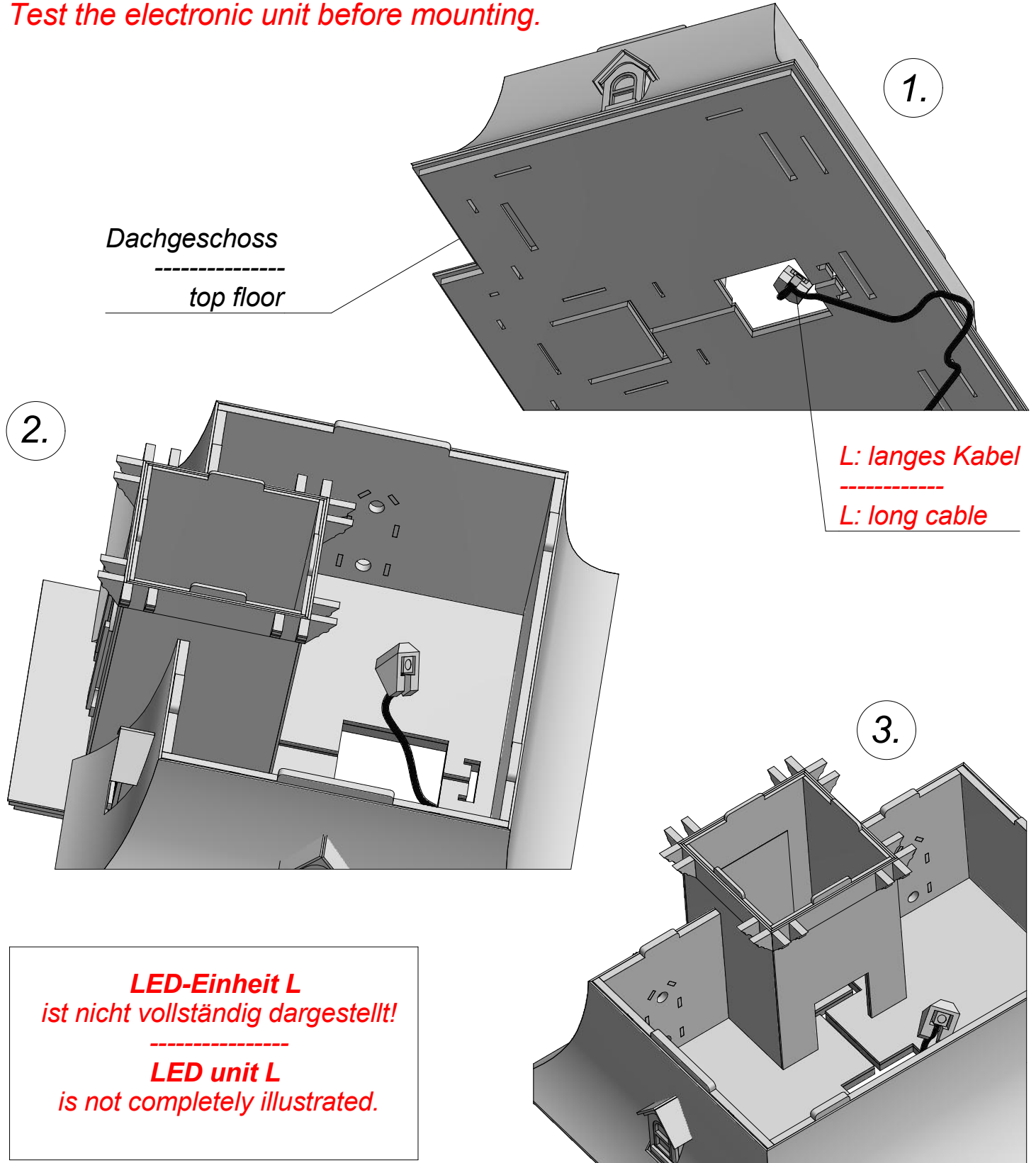

4.

LED-Einheit L
ist nicht vollständig dargestellt!

LED unit L
is not completely illustrated.

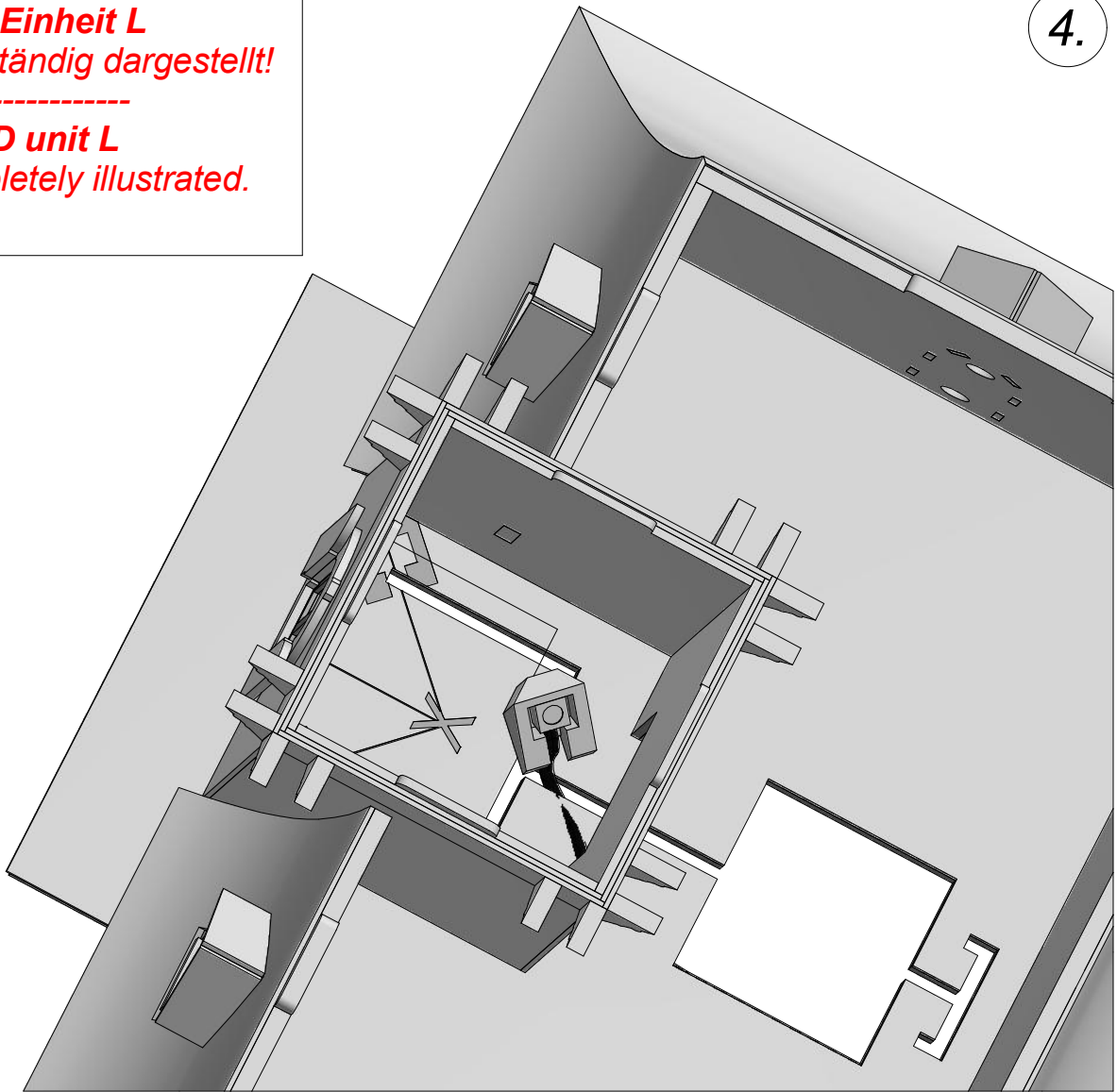

5.

Position nach Wahl!

Position at your choice.

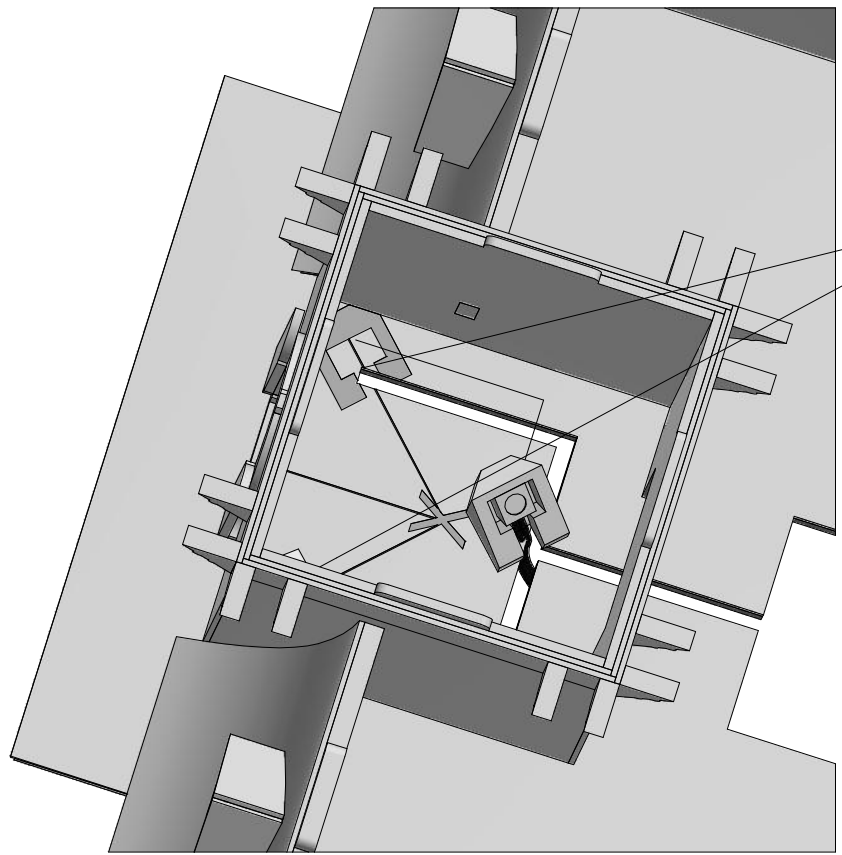

6.

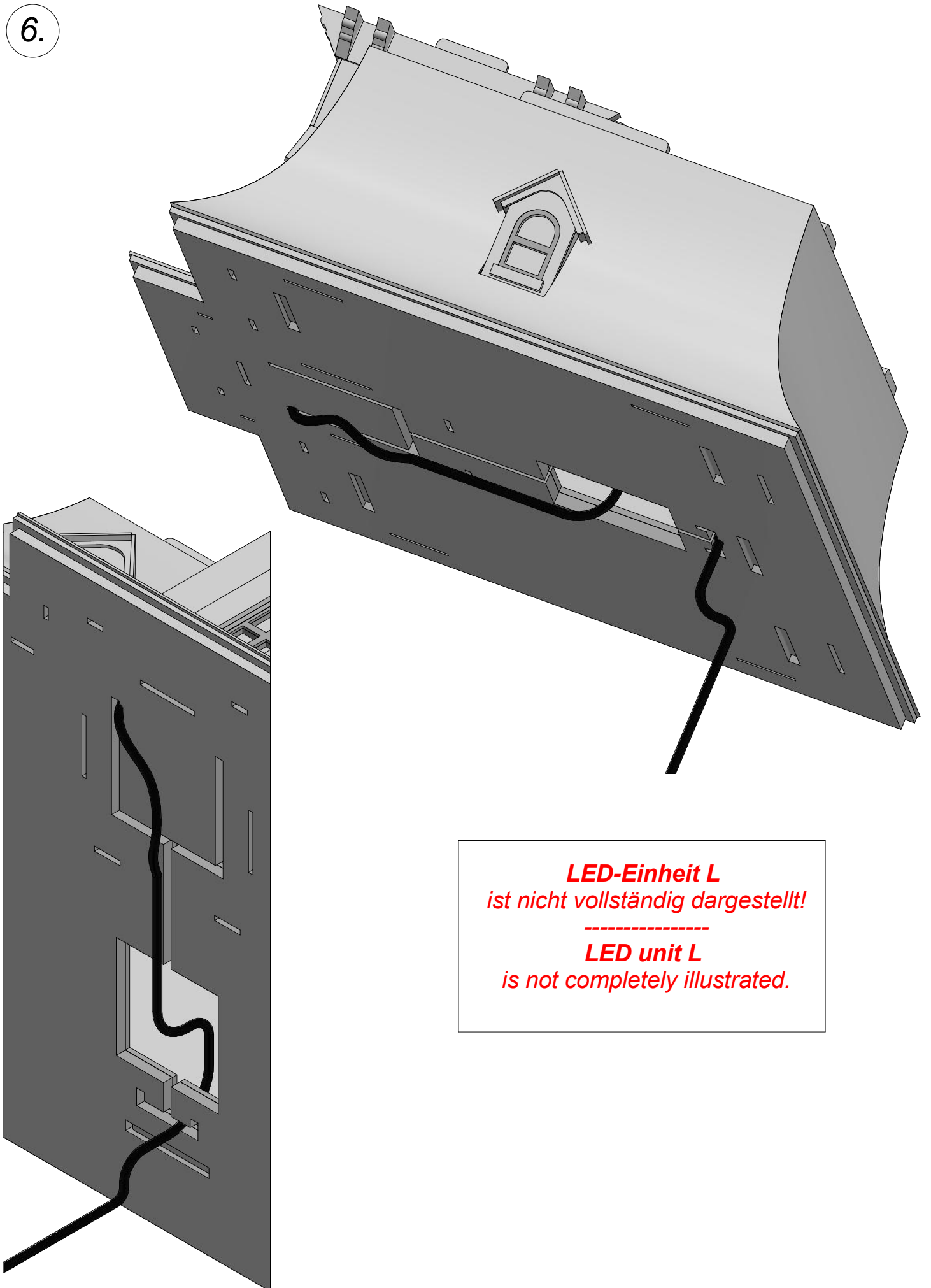

LED-Einheit L
ist nicht vollständig dargestellt!

LED unit L
is not completely illustrated.

7.

Markierung X beachten!

Pay attention to the marking X.

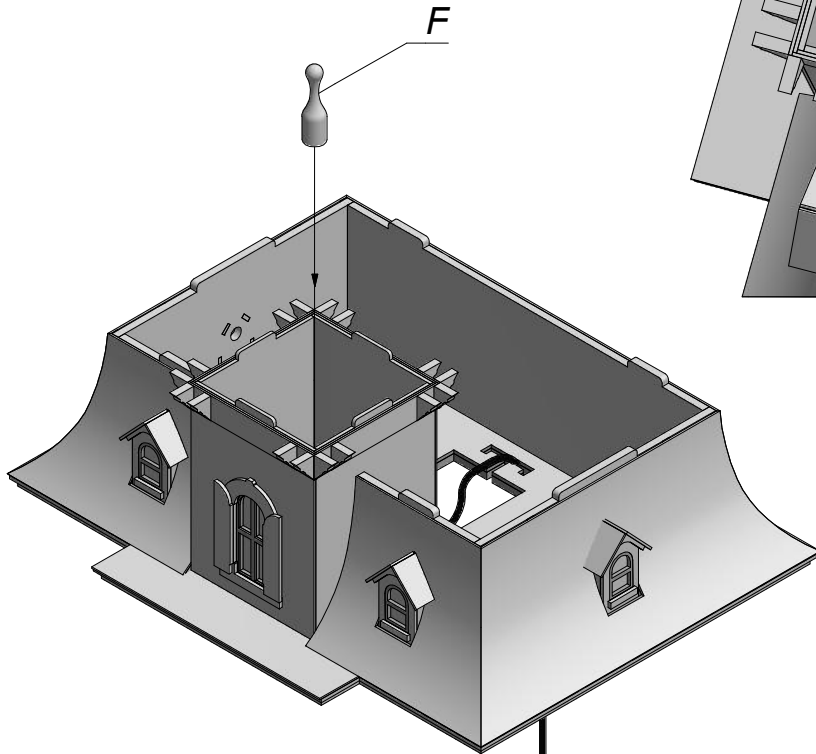
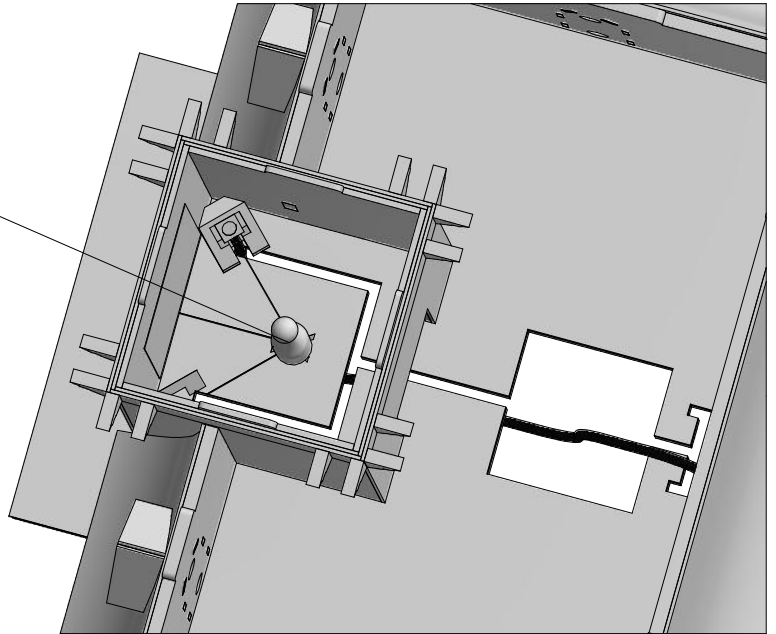

LED-Einheit L
ist nicht vollständig dargestellt!

LED unit L
is not completely illustrated.

8.

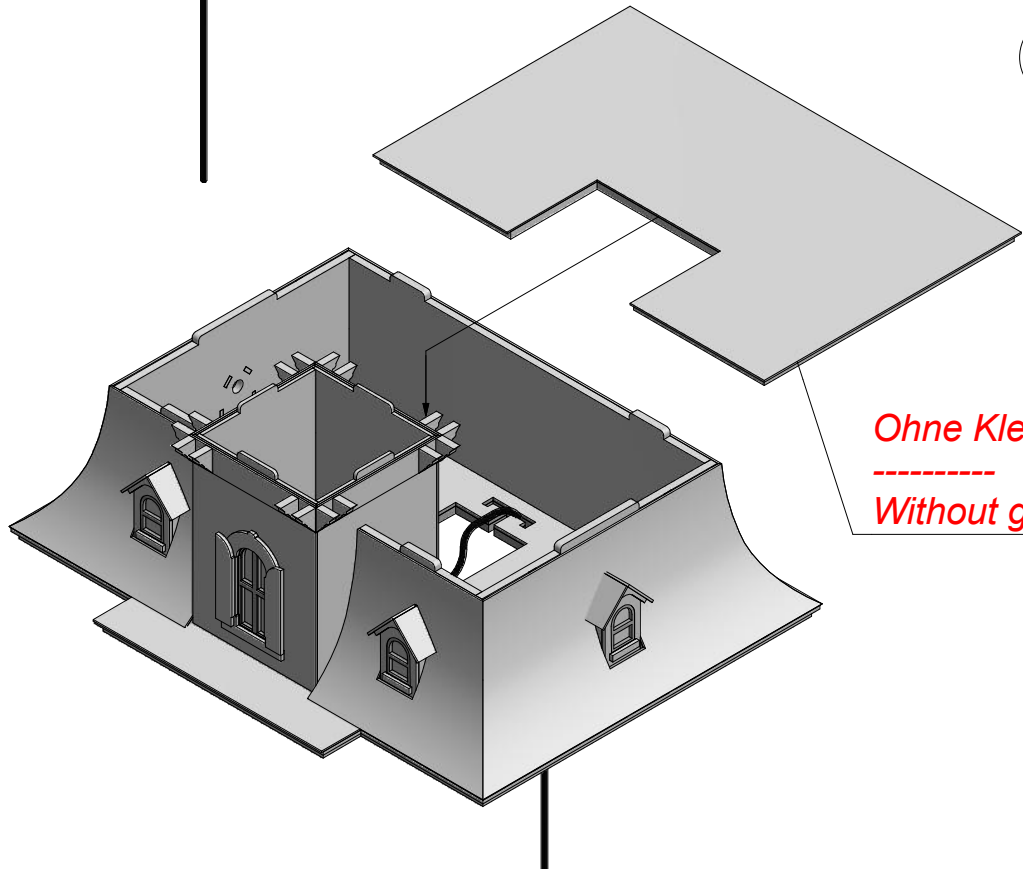

Ohne Kleber!

Without glue!

9.

L durch die mittlere Öffnung ziehen.

Pull L through the hole in the middle.

L: mittleres Kabel

L: middle cable

erstes Obergeschoss

upper floor

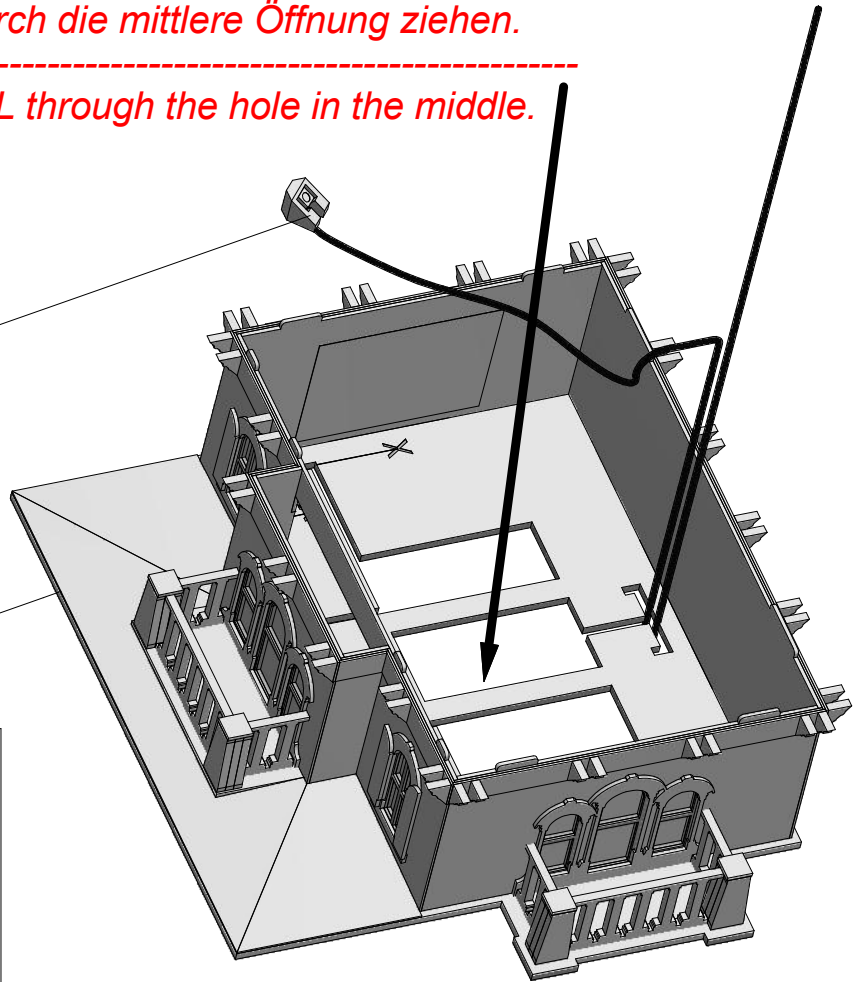

LED-Einheit L
ist nicht vollständig dargestellt!

LED unit L
is not completely illustrated.

Position nach Wahl!

Position at your choice.

10.

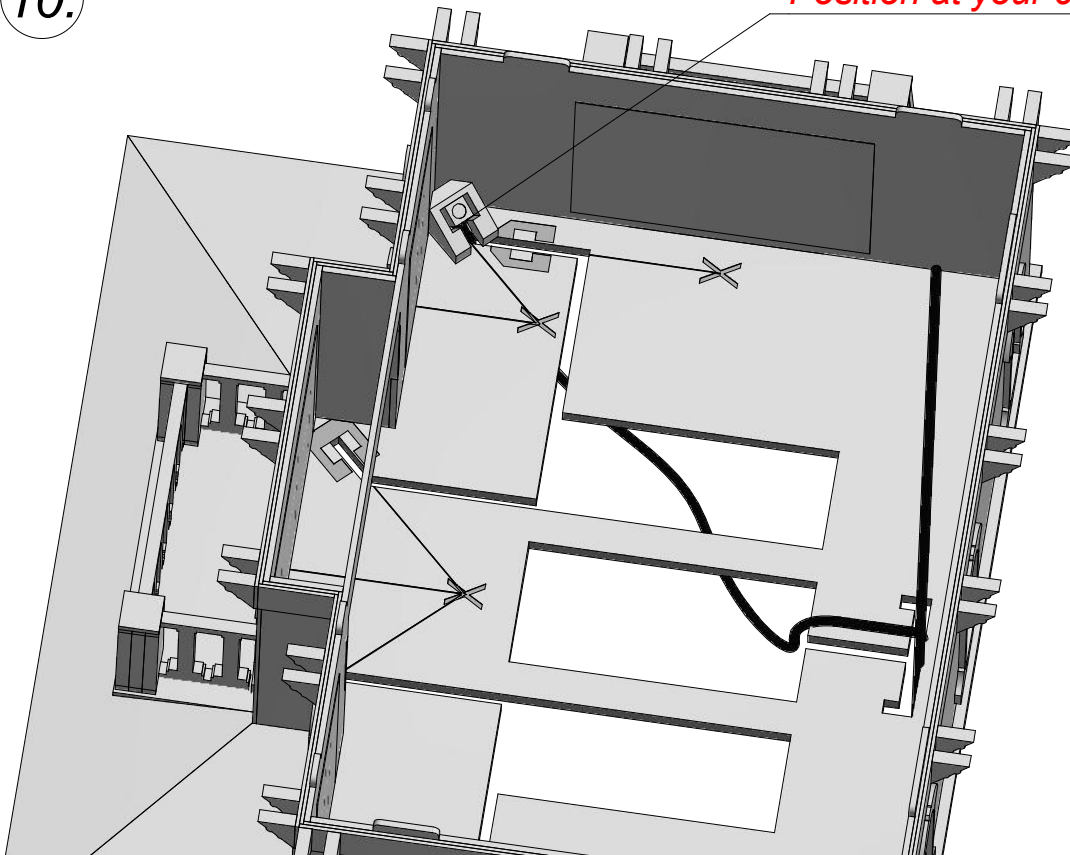

11.

*Zugehörige Markierung X beachten!
Der Linie folgen.*

*Pay attention to the marking X.
Follow the line.*

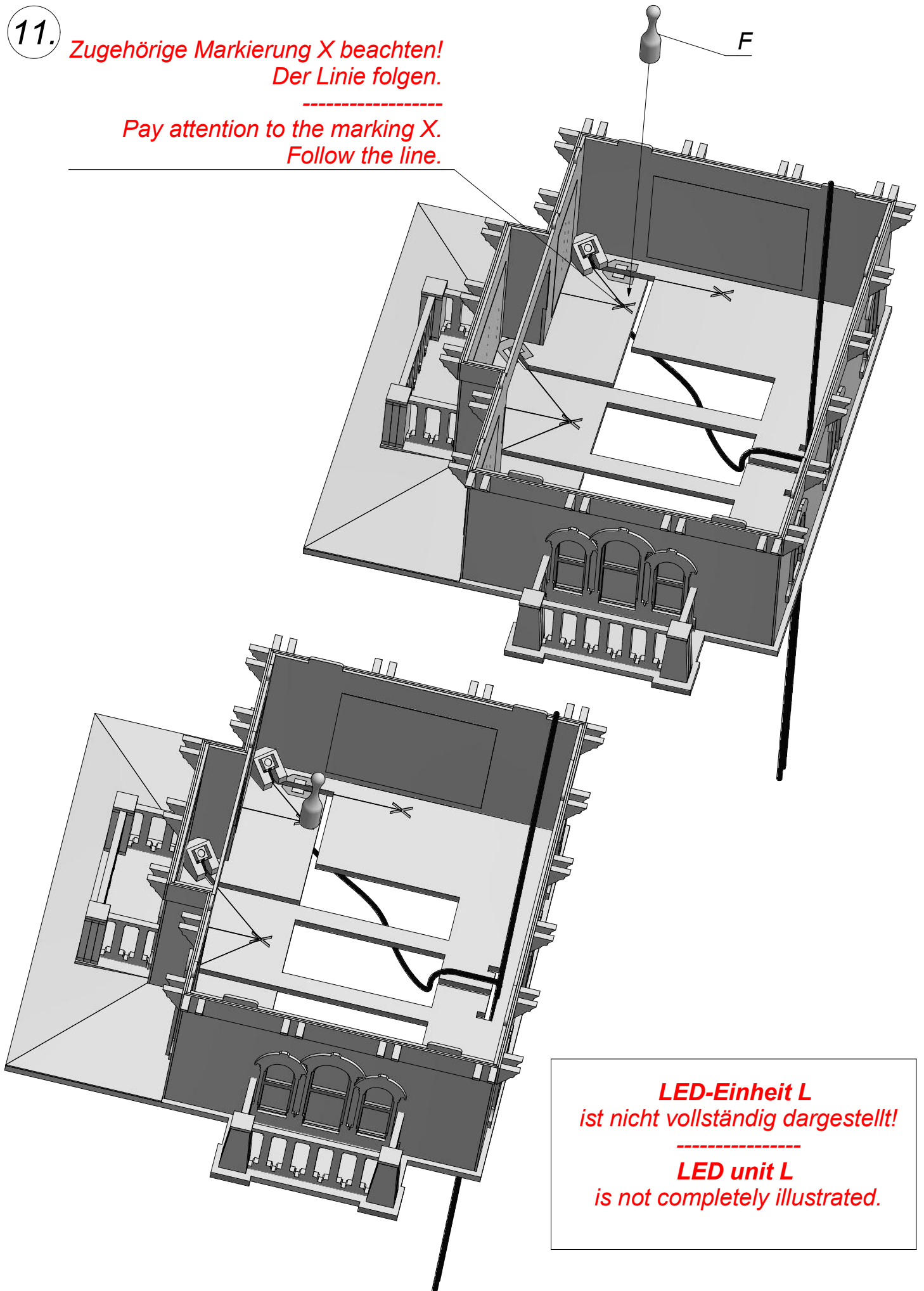

LED-Einheit L
ist nicht vollständig dargestellt!

LED unit L
is not completely illustrated.

12.

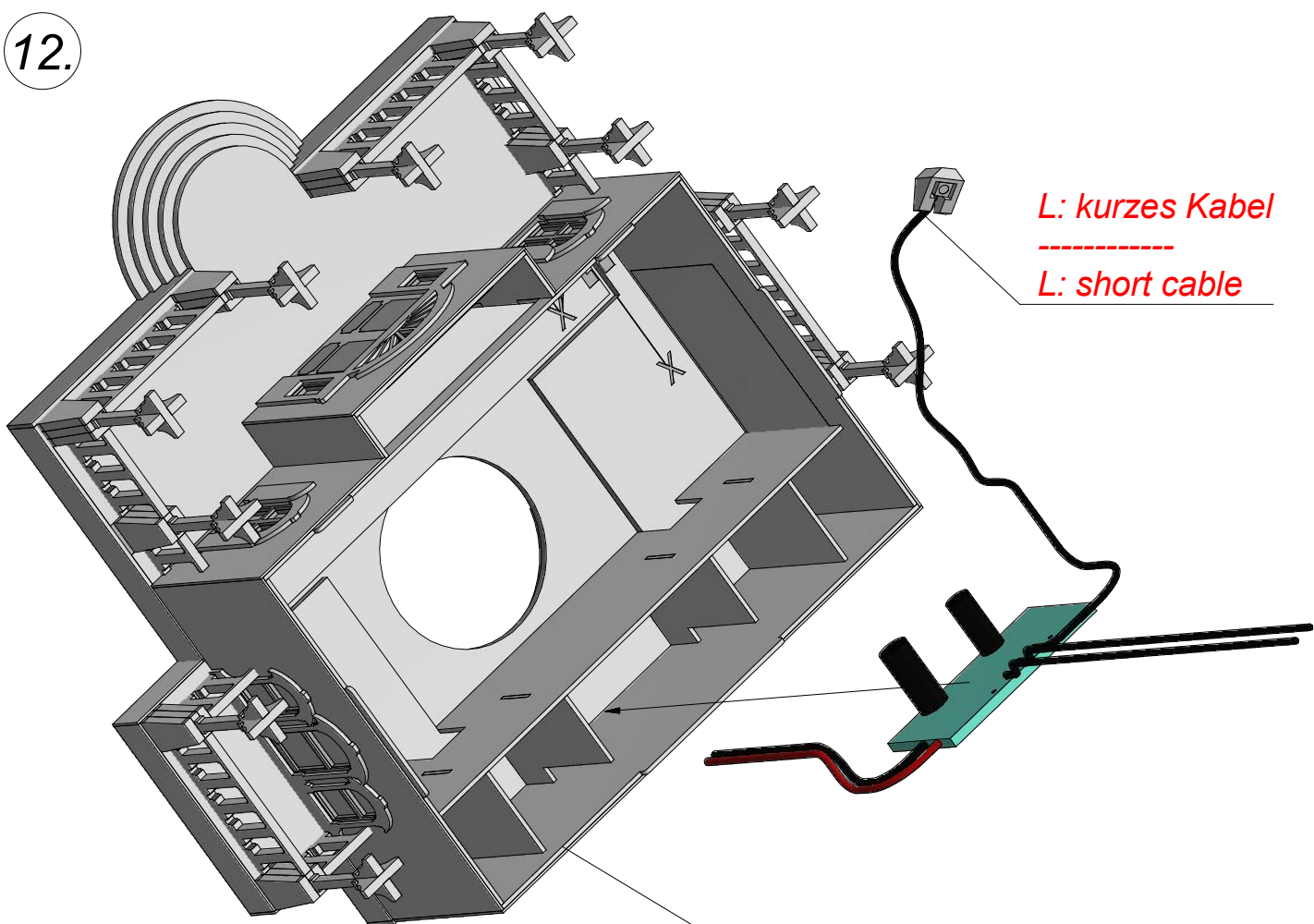

L: kurzes Kabel

 L: short cable

Erdgeschoss

 ground floor

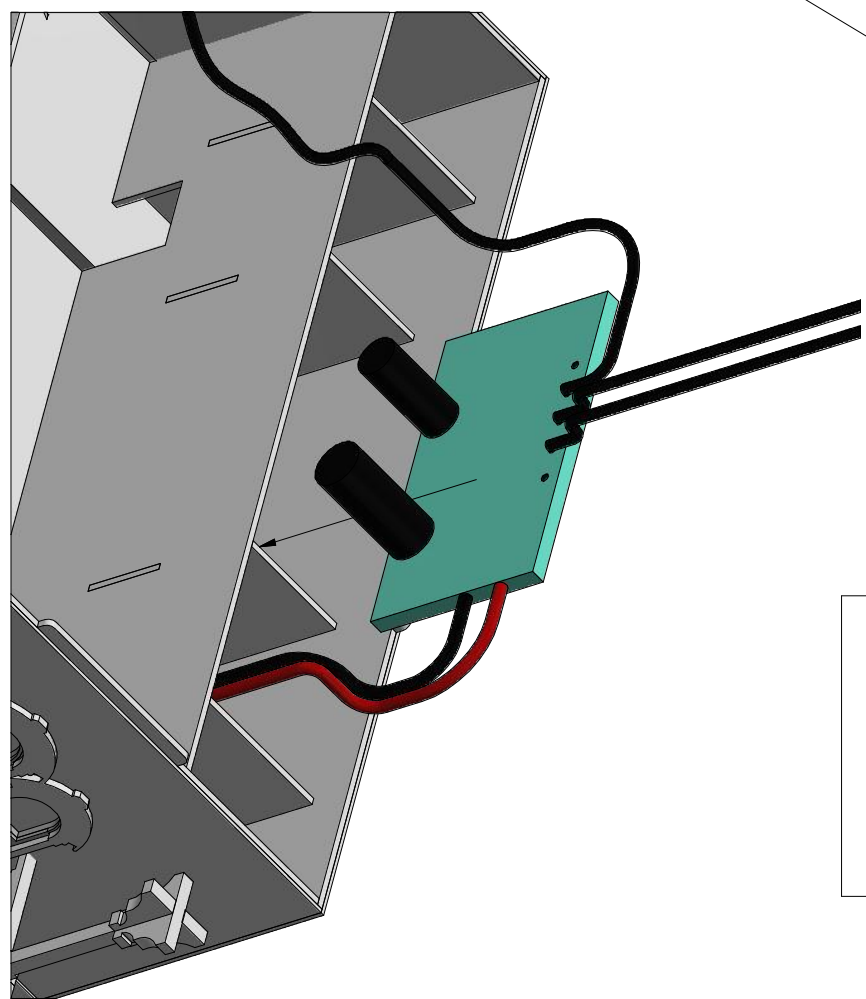

Ohne Kleber!

Without glue!

LED-Einheit L
 ist nicht vollständig dargestellt!

LED unit L
 is not completely illustrated.

13.

Position nach Wahl!

Position at your choice.

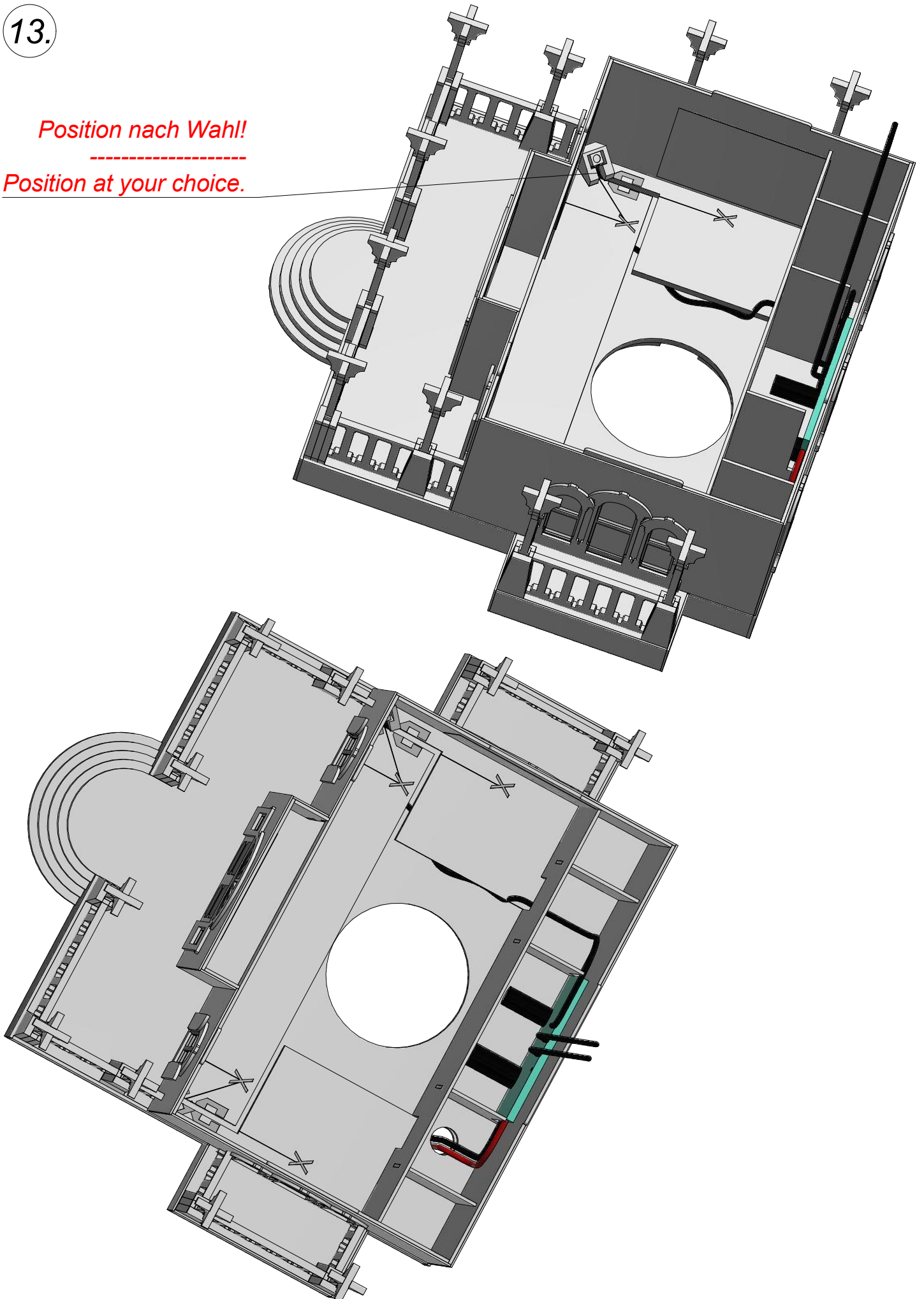

14.

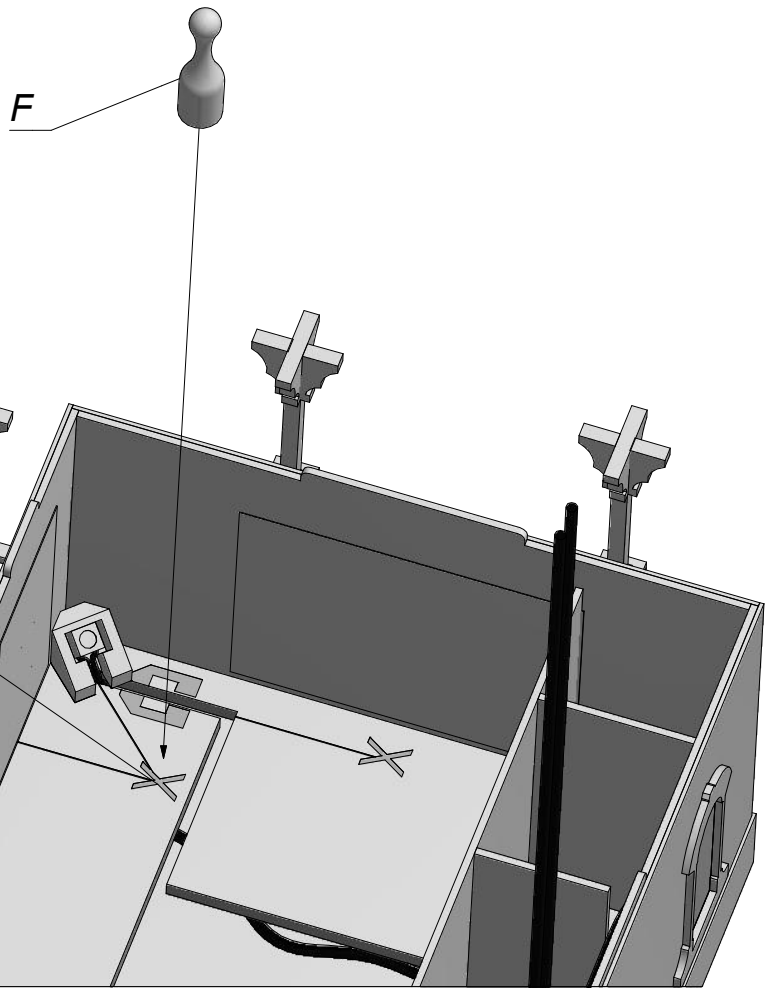

Markierung X beachten!

Pay attention to the marking X.

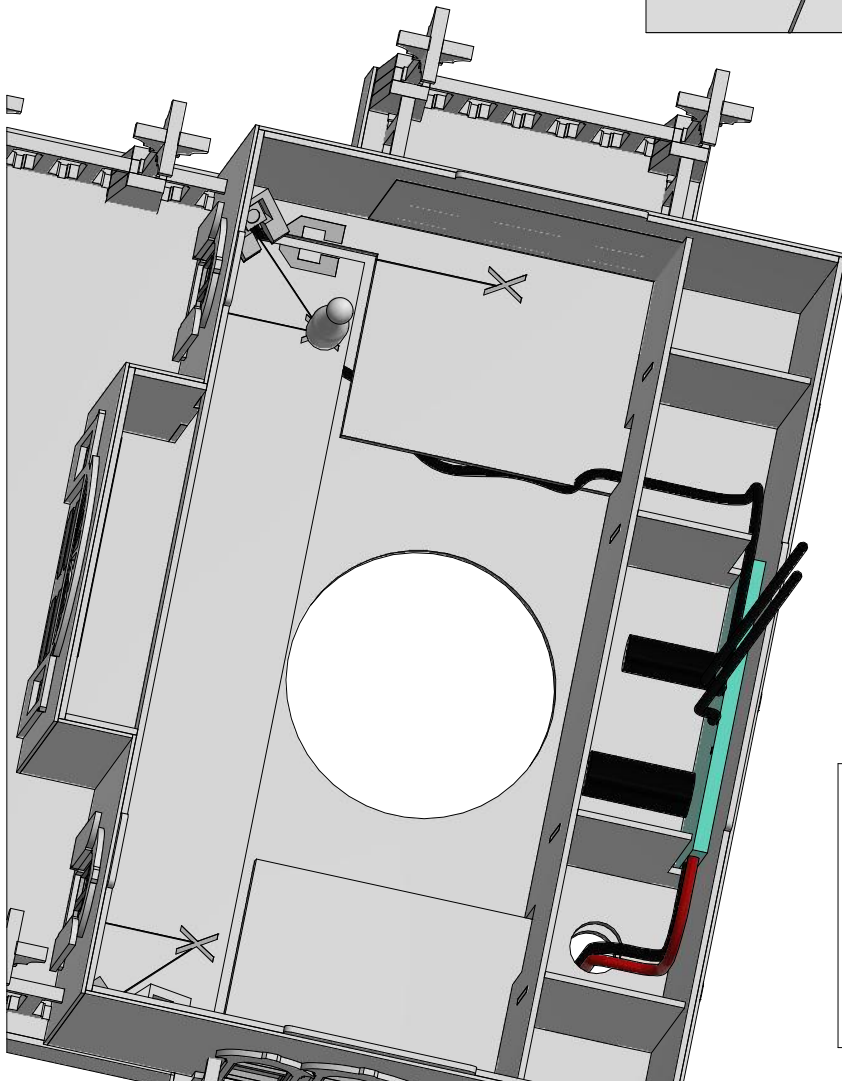

*Vierter Geist (F) wird nach
Wahl positioniert!*

*Position of ghost number 4 (F)
at your choice!*

15.

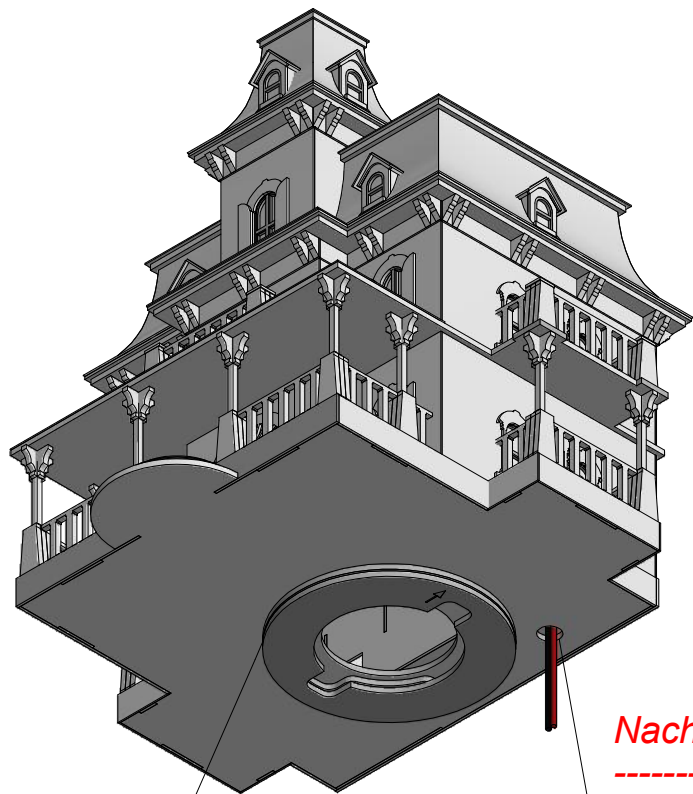
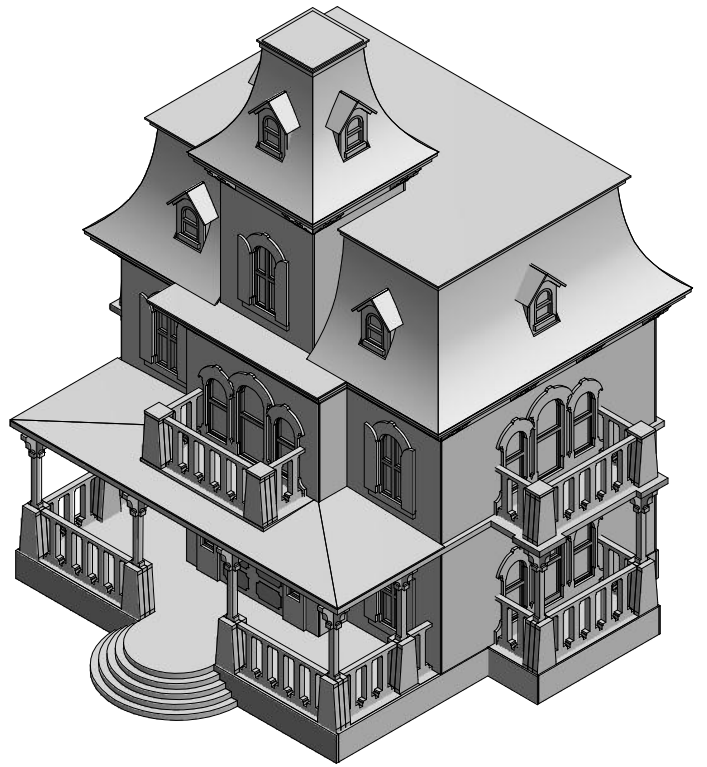
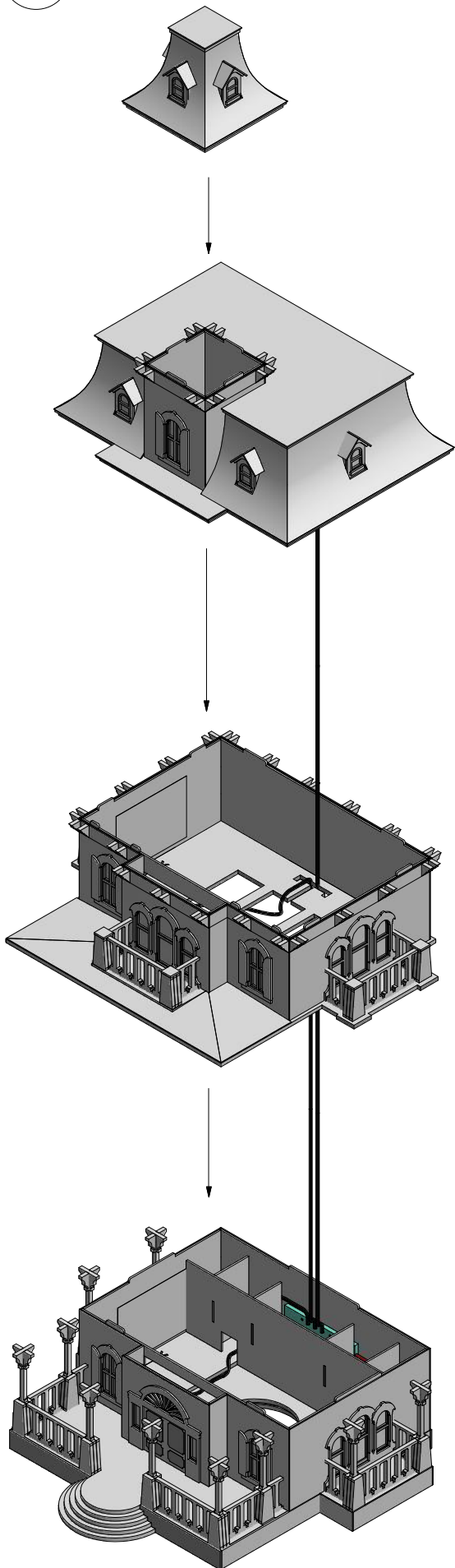

Nach Wahl.

At your choice.

Achtung!
Freimachung auf der Anlage: Ø 70 mm

Attention!
Hole on the model railroad layout: Ø2.76 in.

16.

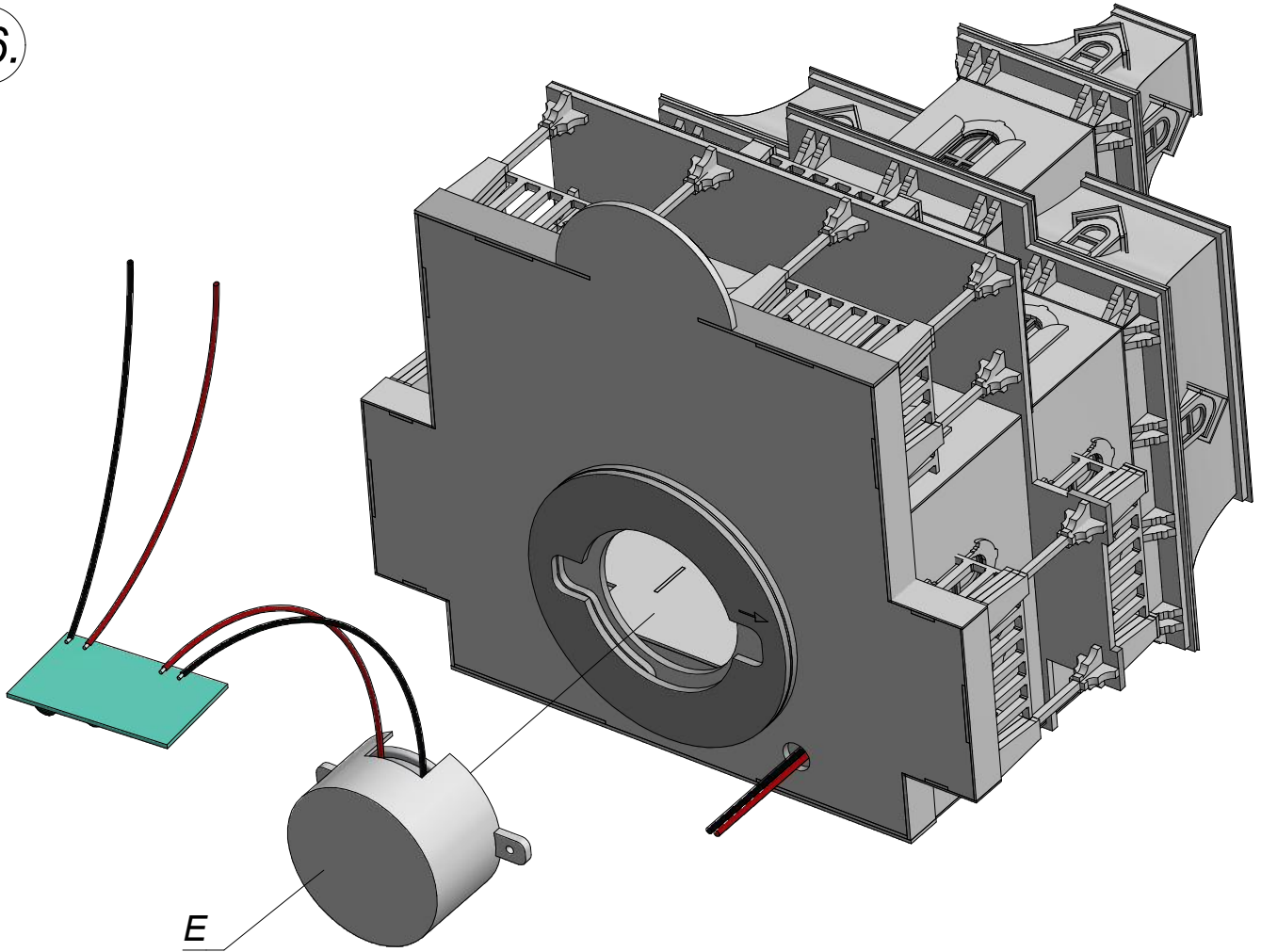

17.

Elektronikeinheit E mit einer 1/4-Drehung befestigen.

Fix electronic unit E with a 1/4-turn.

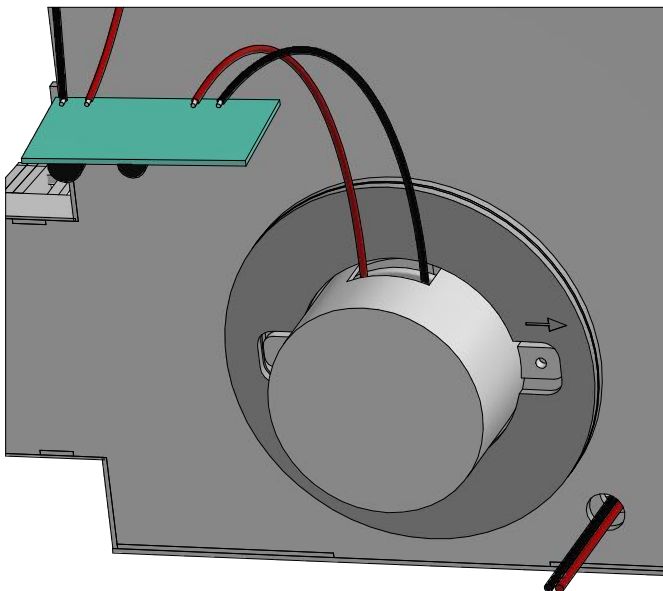

18.

Kabelausgang in Pfeilrichtung.

Cable outlet in direction of arrow.

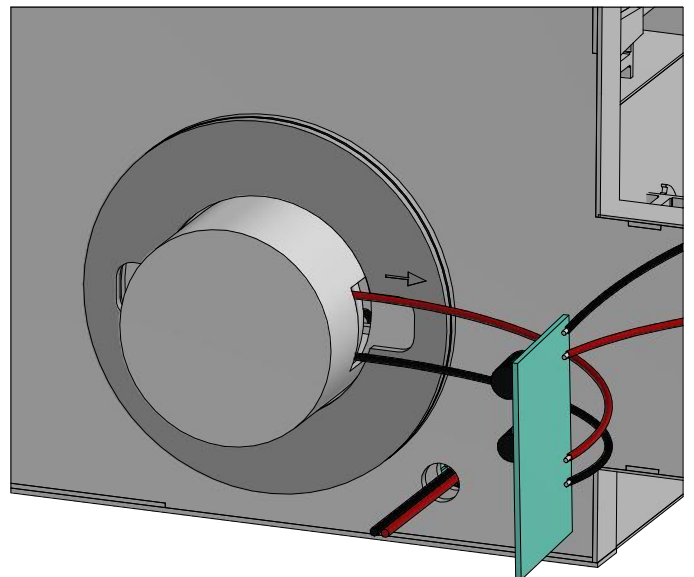

19.

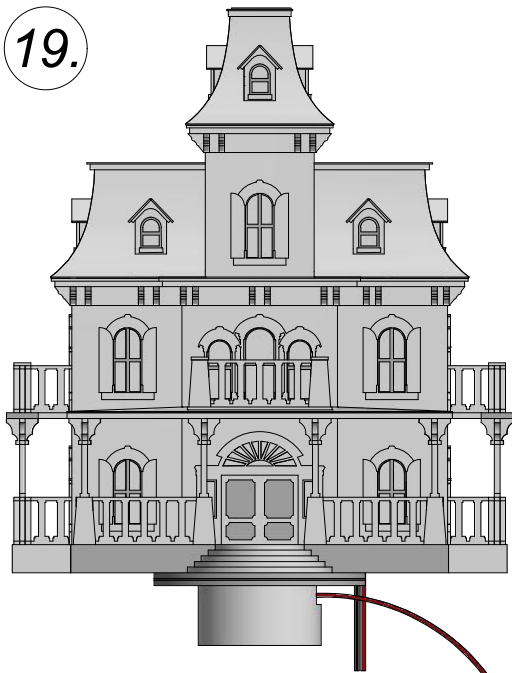

Sound

*Anschluss an einen üblichen
16-V-Modellbahntrafo. Für Gleich-
und Wechselstromanschluss geeignet.*

*The connection is made via a usual
16 V transformer, suitable for AC/DC.*

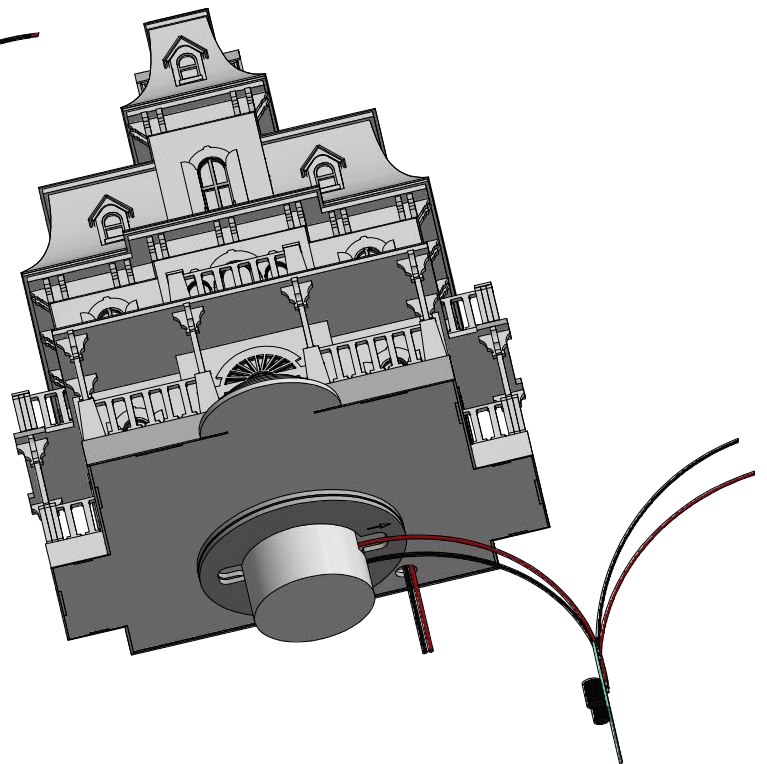

Beleuchtung / Light

Die Elektronik ist bereit für den Betrieb.

Der Anschluss erfolgt an einen Gleich- oder Wechselstrom-Trafo mit maximal 16V Spannung.

Beim Anschluss an einer Gleichstromquelle ist die korrekte Polung zu beachten.

Das rote Kabel an den Pluspol anschließen, das schwarze Kabel an den Minuspol.

Beim Anschluss an eine Wechselstromquelle ist die Polung nicht relevant.

Sobald der korrekte Anschluss erfolgt ist, beginnen die LEDs zu blitzen.

The electronics are ready for operation.

Connection is made to an AC / DC transformer with a maximum voltage of 16 V.

If you connect to a DC source you have to consider the correct polarity.

Connect the red cable to the positive pole and the black cable to the negative pole.

If connection is made to an AC source, you do not have to consider the polarity.

Once you have successfully connected the cables, the LED will light up.

Anschlussplan für NOCH Sound-Szenen

Electrical connection plan for NOCH Sound Scenes

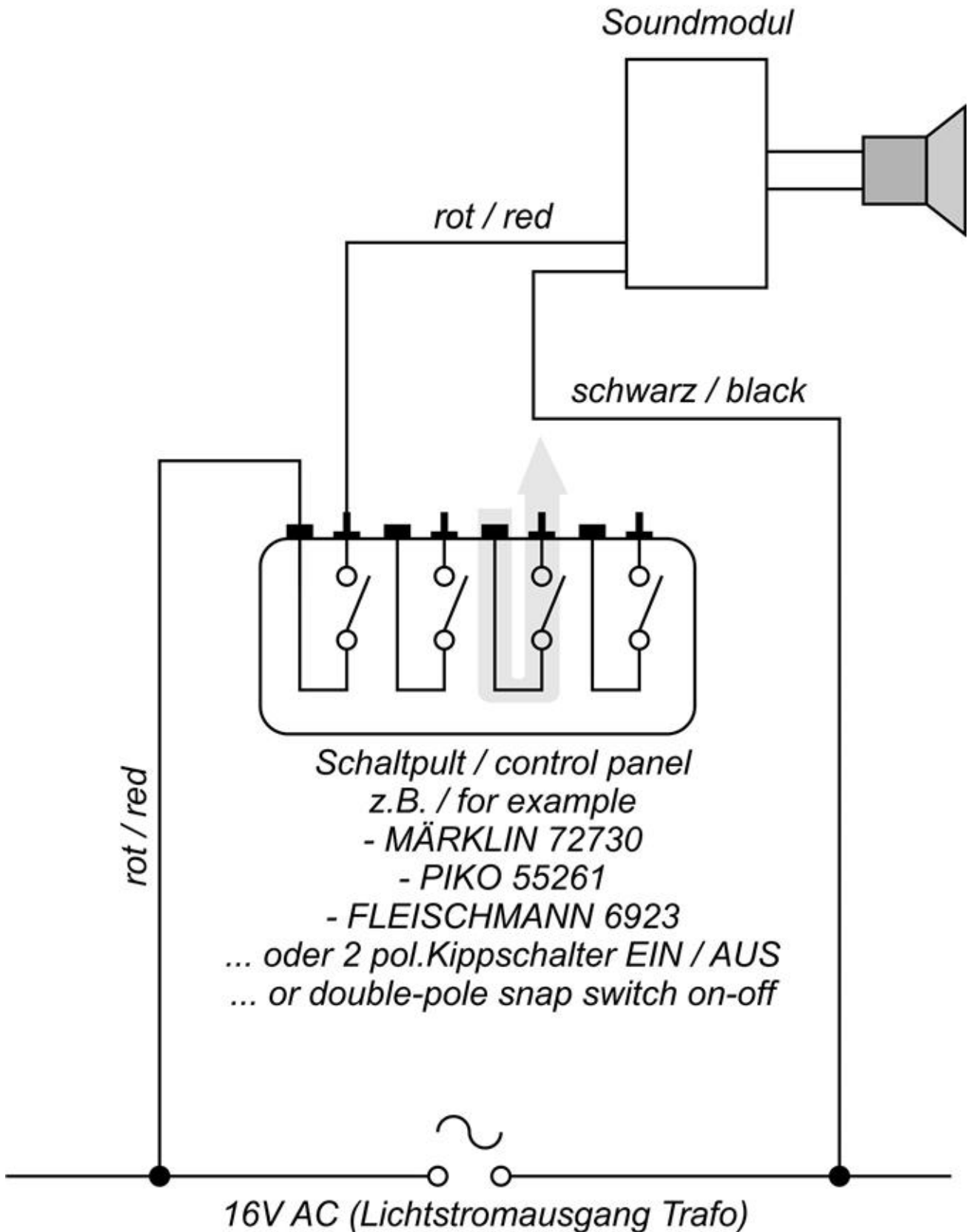



... wie im Original

Sound-Szenen · Sound Scene · Scène sonore · Escena con sonido · Sound scene

D Gebrauchsanleitung

Vor Gebrauch die Sicherheitshinweise und Anleitung genau lesen und beachten. Bei diesem Produkt handelt es sich um einen Modellbau-Bastelartikel und nicht um ein Spielzeug. Für die fachgerechte Anwendung bzw. Weiterverarbeitung ist Werkzeug und Zubehör wie ein scharfes Bastelmesser, eine scharfe Schere und spezielle Kleber nötig.

Die fachgerechte Weiterverarbeitung dieses Modellbauproduktes birgt daher ein Verletzungsrisiko! Das Produkt gehört aus diesem Grund nicht in die Hände von Kindern!

Dieses Produkt sowie Zubehör (Klebstoffe, Farben, Messer, usw.) unbedingt außer Reichweite von Kindern unter 3 Jahren halten! Lassen Sie Kinder nur unter fachkundiger Aufsicht von erwachsenen Modellbauern diese Bausätze bearbeiten.

Beim Basteln mit diesem Produkt unbedingt beachten: Nicht essen, trinken oder rauchen. Farben und Klebstoffe nicht mit Augen, Haut oder Mund in Berührung bringen. Dämpfe nicht einatmen. Von Zündquellen fernhalten. Die Anleitung und Hinweise des Herstellers genau beachten. Erste Hilfe bei Augenkontakt: Auge unter fließendem Wasser ausspülen und dabei offen halten. Umgehend ärztliche Hilfe konsultieren.

ACHTUNG: Diese Produkte sind kennzeichnungspflichtig und dürfen daher nur in Verbindung mit der Original-Verpackung und dieser Anleitung weiter gegeben werden!

Anschluss des Sound-Moduls an eine Stromquelle:

Das schwarze Kabel direkt an einen der beiden Lichtstrom-Ausgänge am Trafo anschließen. Das rote Kabel wird an den anderen Lichtstrom-Ausgang des Trafos angeschlossen. Der Sound ertönt nun dauerhaft. Falls gewünscht, können Sie den Sound schaltbar machen. Dazu kann ein Schalter oder ein Schaltpult (nicht im Lieferumfang enthalten) verwendet werden. Unterbrechen Sie mit diesem Ein- / Aus-Schalter den Stromkreis am roten Kabel.

ACHTUNG: Den Anschluss des Elektronikmoduls niemals unter Spannung vornehmen, vorher Netzstecker des Trafos ziehen. Stellen Sie einen sicheren Stromanschluss her z.B. durch eine Lüsterklemme. Bei einem Wackelkontakt wird die Sicherheits-schaltung des Spannungswandlers aktiviert. Ist dies der Fall, Anschluss überprüfen, Netzstecker ziehen und 10 Sekunden warten. Danach wieder einstecken.

GR USA Instruction manual

Read and follow these safety precautions and instructions carefully before use. This product is a model building item and not a toy.

For appropriate application and use, tools like a sharp cutter, a sharp pair of scissors and special glue are necessary. Therefore, appropriate work with this model building product does pose risk of injury! For that reason this product is not for children!

Keep this product as well as all accessories (glue, paints, cutter etc.) out of reach of children under 3 years of age! Let children build this kit only if supervised by a competent adult modeller.

For the use of paints and glues please follow these safety precautions carefully: Do not eat, drink or smoke. Avoid any contact with eyes, skin or mouth. Do not breathe any vapours. Keep away from ignition sources. Follow the instructions and safety precautions of the manufacturer carefully. First aid for contact with eyes: Flush the eye with clean water holding the eyelid open. Immediately consult medical advice.

ATTENTION: These products are subject to the accurate labelling and are to be forwarded only with the original packing and this instruction manual!

How to connect the sound module to a power source:

Connect the black cable directly to one of the two light current outputs of the transformer. Connect the red cable to the other light current output of the transformer. Now you can hear a permanent sound. If desired you can make the sound switchable. For this you can use a switch or a control panel (not included in the scope). Interrupt the electric circuit with this on/off switch at the red cable.

ATTENTION: Never connect the electronic module when voltage is connected to it; pull out the plug of the transformer before. Assemble a safe electrical connection e.g. using an insulating screw joint. In case of a loose connection the electric safety device of the voltage transformer will be activated. If this is the case, check the connection, pull out the power plug and wait for 10 minutes. Then plug it in again.

F Instructions d'emploi

Avant d'utiliser ce produit, veuillez lire et suivre attentivement les consignes de sécurité et le mode d'emploi.

Cet article est un produit de bricolage pour modélisme et n'est pas un jouet. Pour le montage, des outils tels une lame aiguisée, des ciseaux aiguisés ainsi qu'une colle spéciale sont nécessaires. De ce fait, un risque de blessure est possible! Pour cette raison, tenir ce produit hors de portée des enfants!

Tenir absolument ce produit et les accessoires (colle, peintures, lames etc.) hors de portée des enfants de moins de 3 ans! Ne pas laisser les enfants assembler ces kits sans surveillance d'un adulte compétent.

Pour l'utilisation des colles et des peintures, veuillez suivre les précautions suivantes: Ne pas manger, boire ou fumer lors de la manipulation. Eviter tout contact avec les yeux, la peau et la bouche. Ne pas inhaler les vapeurs. Tenir à l'écart des sources inflammables. Veuillez suivre attentivement le mode d'emploi et les indications du fabricant. Premiers secours en cas de contact avec les yeux: Rincer immédiatement et abondamment à l'eau en les maintenant ouverts et consulter un ophtalmologiste.

ATTENTION : Ces produits sont soumis à l'étiquetage et donc ils doivent être transmis seulement sous emballage d'origine et avec ces instructions !

L'alimentation électrique du module de son :

Le câble noir est raccordé directement à l'une de deux sorties d'éclairage du transformateur. Le câble rouge est branché à l'autre sortie d'éclairage du

transformateur. Maintenant, le son est émis de manière continue. Si désiré, le son peut être commuté en utilisant un interrupteur ou un pupitre de commande (ne pas inclus). Cet interrupteur vous permet de disjoncter le circuit électrique au câble rouge.

ATTENTION : Ne branchez jamais le module électronique sous tension ! Il faut retirer la fiche secteur avant. Faites une bonne alimentation électrique, p.ex. par un domino. En cas d'un faux contact, le circuit de sécurité du transformateur de tension est activé. Dans ce cas, il faut vérifier le branchement, retirer la fiche secteur et attendre pour 10 secondes. Ensuite, la rebranchez.

Instrucciones de empleo

Antes de utilizar este producto, leer atentamente las instrucciones de seguridad y el modo de empleo.

Este producto es un artículo de bricolaje para modelismo y no un juguete. Para la utilización o elaboración posterior correcta se necesitan herramientas y accesorios como un cuchillo afilado, tijeras puntiagudas y pegamento especial. El tratamiento correcto de este producto posee riesgos escondidos de lesión. ¡Por eso mantener este producto fuera del alcance de los niños!

¡En ningún momento dejar el producto así como los accesorios (pegamento, colores, cuchillos, etc.) al alcance de niños menores de 3 años! La utilización de este producto por niños deberá realizarse solo bajo vigilancia de un adulto modelista.

Durante el bricolaje con este producto atender en todo caso las indicaciones siguientes: no comer, beber ni fumar. Evitar el contacto de colores o pegamento con la piel, boca y los ojos. Evitar la inhalación de vapores. No exponer a fuentes de calor. Seguir exactamente las instrucciones e indicaciones del fabricante. En caso de contacto con los ojos lavar con abundante agua manteniendo los párpados abiertos y buscar atención médica inmediatamente.

¡ATENCIÓN: Estos productos tienen obligación de ser etiquetados y solo deben ser transmitidos con el embalaje original y estas instrucciones!

Conexión del módulo de sonido a una fuente de alimentación:

Conecte el cable negro directamente a una de las dos salidas del flujo luminoso eléctrico del transformador. Conecte el cable rojo a la otra salida del flujo luminoso de electricidad del transformador. El sonido sonará de forma permanente. Si lo desea, puede hacer que el sonido suene cuando lo desee. Para ello necesitará utilizar un interruptor o panel de mando (no incluido). Accionando o apagando el interruptor se accionará o interrumpirá la corriente en el cable rojo.

ADVERTENCIA: Nunca haga la conexión del módulo electrónico mientras esté conectado, antes desconecte el transformador. Hacer una conexión eléctrica segura utilizando por ejemplo una regleta. En caso de falso contacto, se activa el transformador de seguridad del convertidor de tensión. Si se da el caso, comprobar la conexión, desconecte la corriente de alimentación y espere 10 segundos. A continuación, vuelva a conectarlo.

Gebruiksaanwijzingen

Voor gebruik de veiligheidswaarschuwingen en instructies goed lezen en in acht nemen. Dit product is een modelbouw-knutsel-artikel en geen speelgoed. Voor de juiste toepassing en verwerking is gereedschap en toebehoren zoals een scherp mes, een scherpe schaar en speciale lijm nodig. Vakkundige verwerking van dit modelbouwproduct vormt kans op letsel! Daarom buiten bereik van kinderen houden!

Dit product en toebehoren (lijm, verf, messen enz.) absoluut buiten bereik van kinderen onder de 3 jaar houden! Laat kinderen alleen onder vakkundige begeleiding van een volwassen modelbouwer deze bouwset bewerken.

Let bij het in elkaar zetten van dit product absoluut op: niet eten, drinken of roken. Verf en lijm niet in aanraking brengen met ogen, huid of mond. Niet inademen. Verwijderd houden van ontstekingsbronnen. De handleiding en instructies van de fabrikant nauwkeurig opvolgen. Eerste hulp bij oogcontact: ogen open houden en met stromend water uitspoelen en. Direct een arts raadplegen.

LET OP: deze producten zijn geëtiketteerd en mogen daarom alleen in de originele verpakking en deze handleiding worden doorgegeven!

Aansluiten van de sound-module op een stroombron:

De zwarte draad direct op één van de beide lichtstroomuitgangen van de trafo aansluiten. De rode draad wordt aan de andere lichtstroomuitgang van de trafo aangesloten. Het geluid laat zich nu continu horen. Indien gewenst kan het geluid schakelbaar gemaakt worden. Hiervoor kan een schakelaar of schakelblok (niet inbegrepen) worden gebruikt. Onderbreek met deze aan/uit schakelaar de stroomkring op de rode draad.

LET OP: Het aansluiten van een elektronikamodule nooit onder spanning doen, eerst de netstekker van de trafo uit het stopcontact halen. Draag zorg voor een deugdelijke stroomaansluiting, bv. door een kroonsteen. Bij een slecht contact wordt de veiligheidsschakeling van de converter geactiveerd. Is dit het geval, aansluitingen controleren, netstekker losmaken en 10 seconden wachten.

Modellbauartikel, kein Spielzeug!

Model building item, not a toy!

Not suitable for children under 14 years!

Article de modélisme. Ceci n'est pas un jouet.

Articolo di modellismo, non è un giocattolo!

Artículo para modelismo ¡No es un juguete!

Artigo para modelismo.

Este artigo não é um brinquedo!

Výrobek určený pro modeláře, nejedná se o hračku!

Modelbouwartikel, geen speelgoed!

Made in Vietnam.



... wie im Original

NOCH GmbH & Co. KG

Lindauer Straße 49

D-88239 Wangen im Allgäu

Tel.: +49 - 75 22 - 97 80-0

Fax: +49 - 75 22 - 97 80-80

E-Mail: info@noch.de

www.noch.de - www.noch.com

